

UNLESS OTHERWISE SPECIFIED: DIMENSIONS ARE IN INCHES SURFACE FINISH: 3D PRINTED TOLERANCES: LINEAR: ANGULAR:				FINISH:		DEBURR AND BREAK SHARP EDGES		DO NOT SCALE DRAWING		REVISION	
DRAWN				NAME		SIGNATURE		DATE		TITLE: BACKBOARD	
CHK'D											
APP'VD											
MFG											
Q.A								MATERIAL: ABS		DWG NO. LS10B001	
								WEIGHT: 0.19		SCALE: 1:2	
										SHEET 1 OF 1	

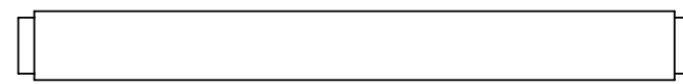

ITEM NO.	PART NUMBER	DESCRIPTION	QTY.
1	LS10B011L		1
2	LS10B016		3
3	LS10B020		1
4	LS10B013		2

UNLESS OTHERWISE SPECIFIED: DIMENSIONS ARE IN MILLIMETERS				FINISH:		DEBURR AND BREAK SHARP EDGES		DO NOT SCALE DRAWING		REVISION
TOLERANCES: LINEAR: ANGULAR:										
DRAWN				NAME	SIGNATURE	DATE			TITLE:	
CHK'D										
APPV'D										
MFG										
Q.A.							MATERIAL:		DWG NO.	
							WEIGHT:		Conveyor 2	
									A2	
							SCALE:1:5		SHEET 1 OF 1	

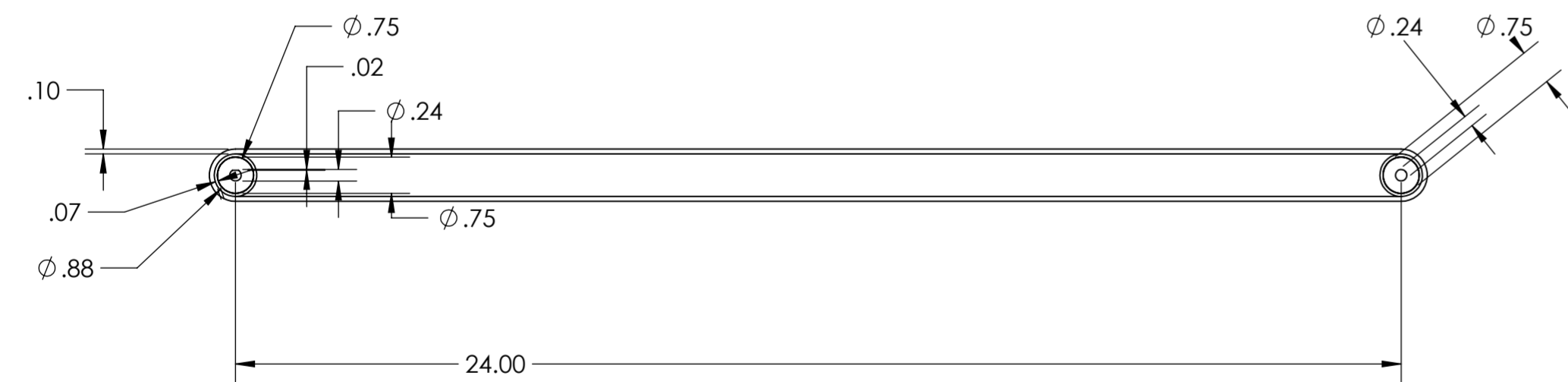
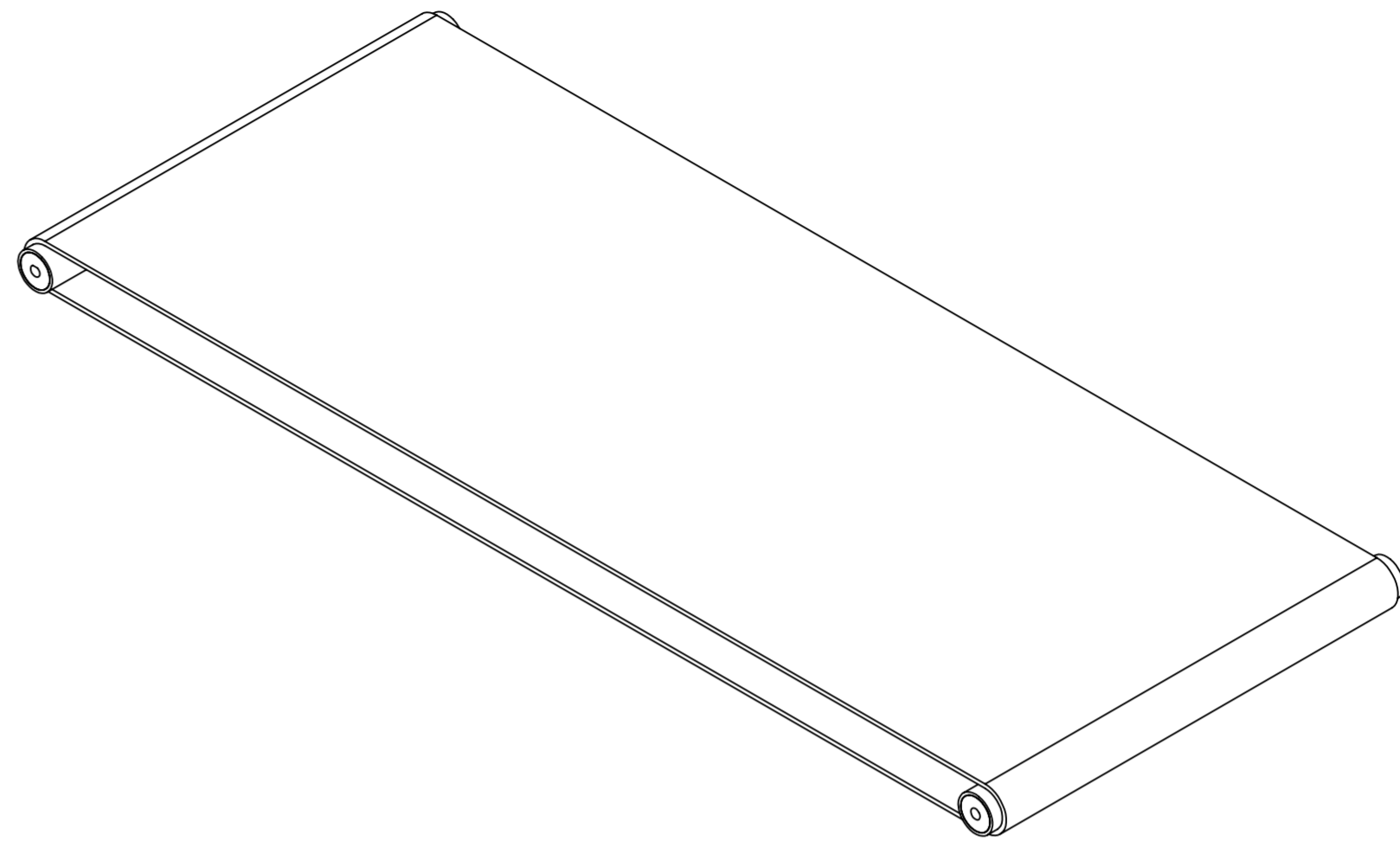
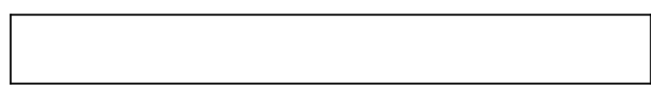
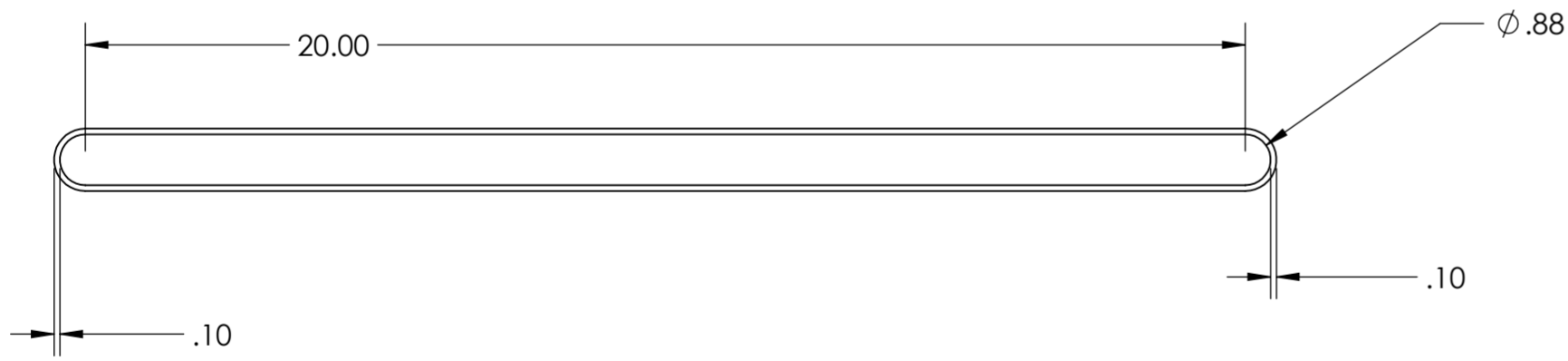
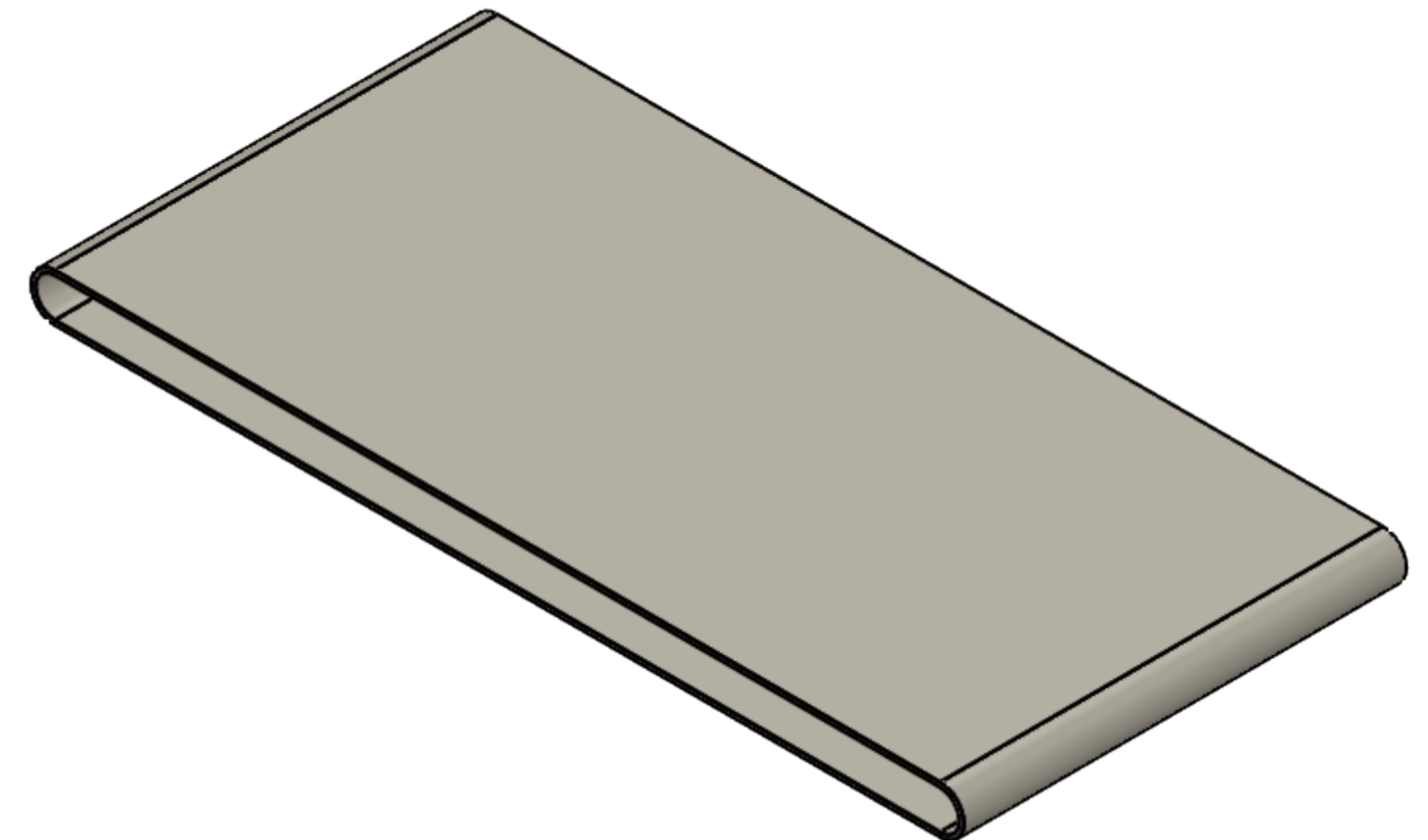
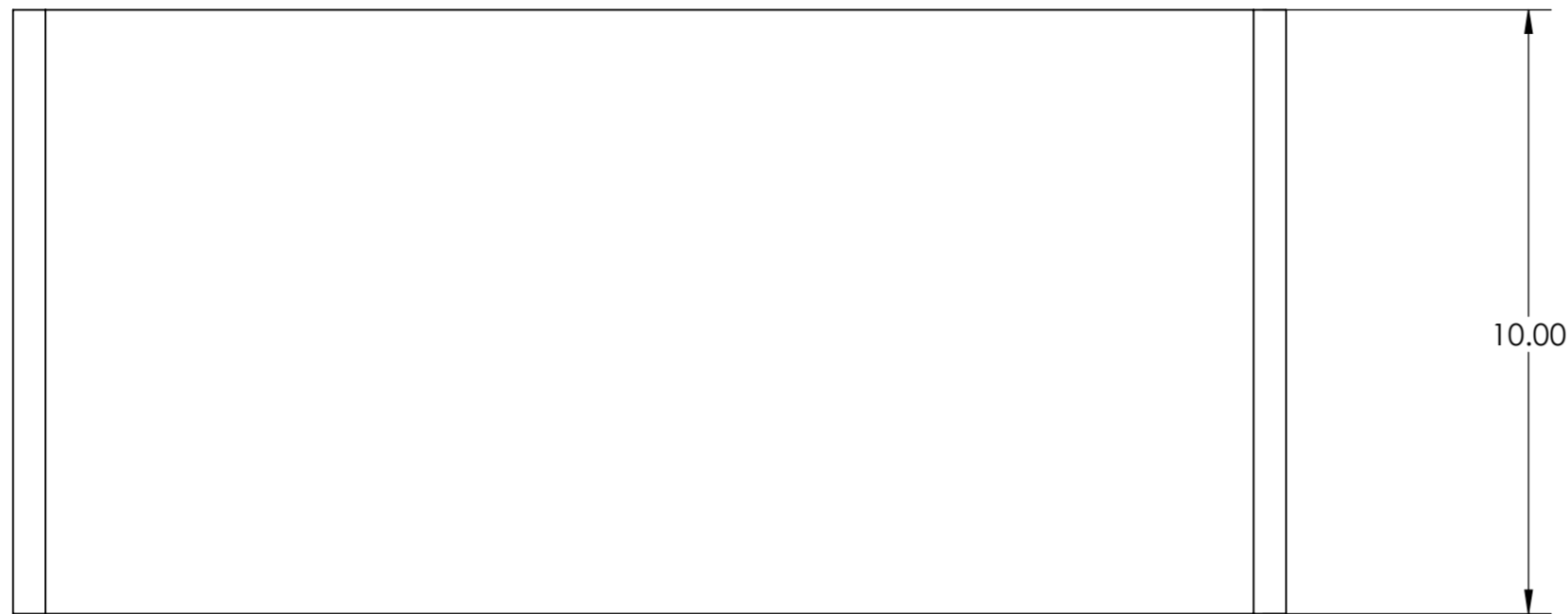

UNLESS OTHERWISE SPECIFIED: DIMENSIONS ARE IN INCHES SURFACE FINISH:				FINISH:		DEBURR AND BREAK SHARP EDGES		DO NOT SCALE DRAWING		REVISION	
								TITLE: UPPER CONVEYOR BELT			
DRAWN		NAME		SIGNATURE		DATE		MATERIAL: Corrugated Paper		DWG NO. LS10B011U	
CHK'D								WEIGHT: 0.24		SCALE: 1:5	
APP'VD										SHEET 1 OF 1	
MFG										A2	
Q.A											

12 11 10 9 8 7 6 5 4 3 2 1

H
G
F
E
D
C
B
A

H
G
F
E
D
C
B
A

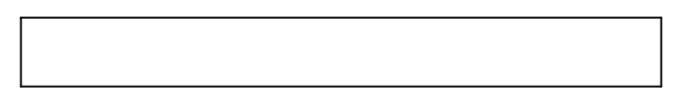
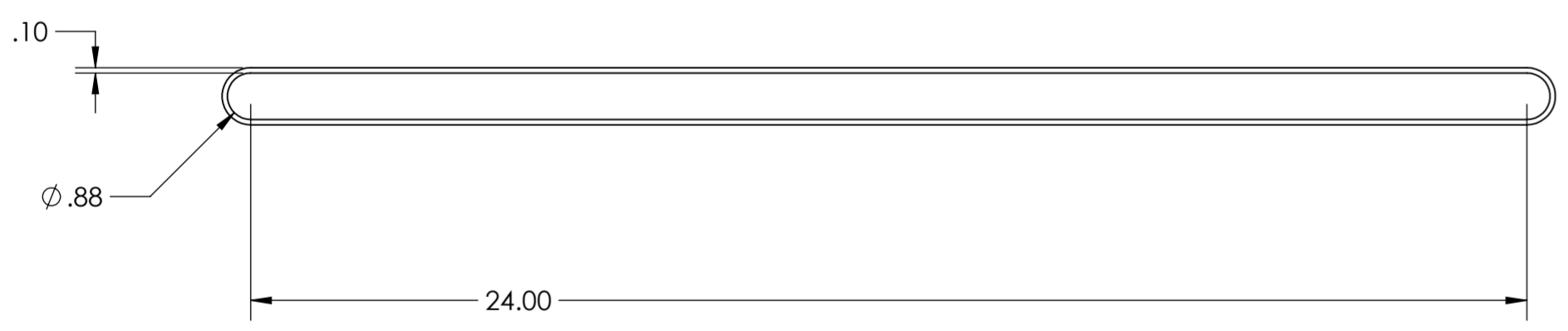
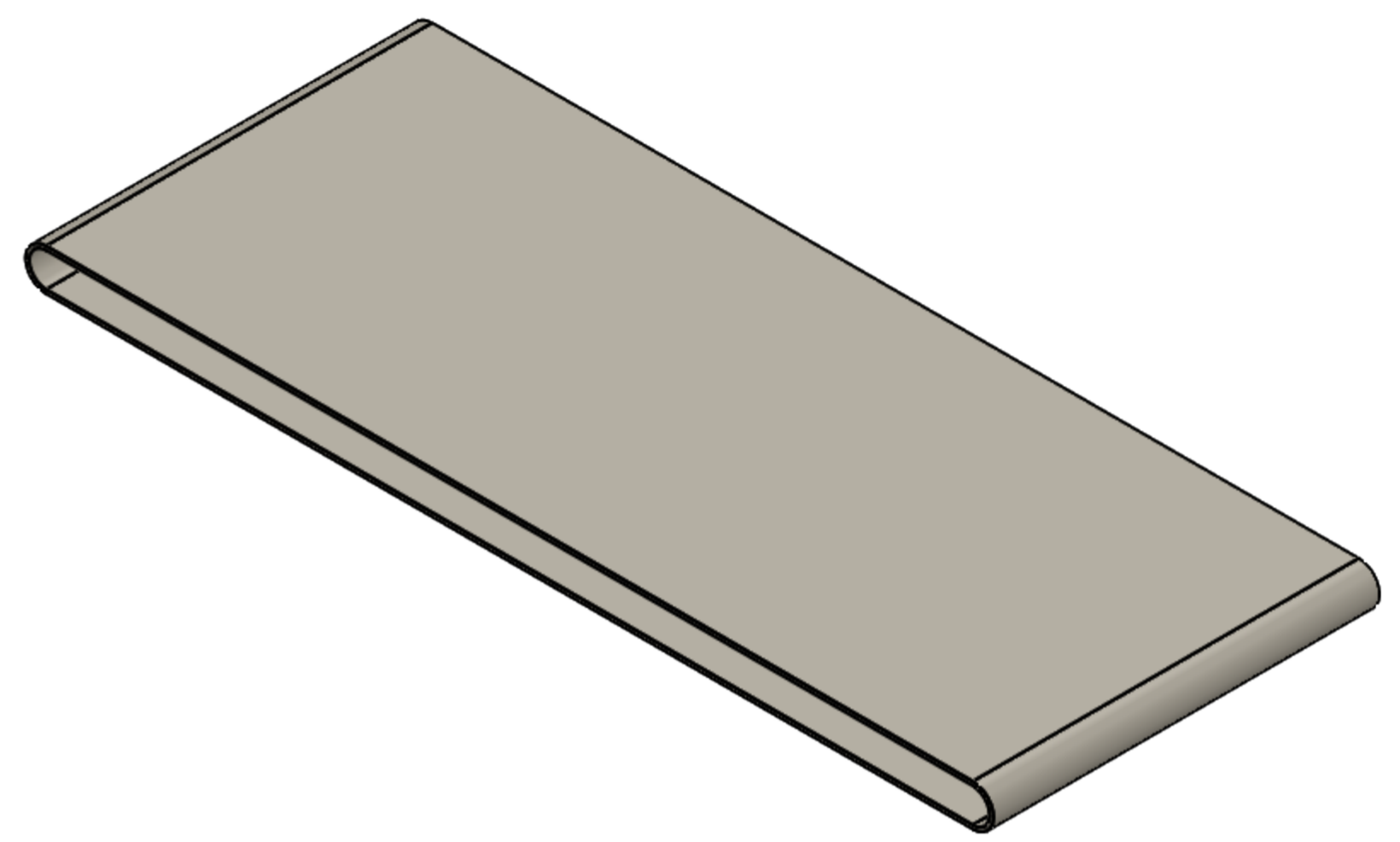

UNLESS OTHERWISE SPECIFIED: DIMENSIONS ARE IN INCHES				FINISH:		DEBURR AND BREAK SHARP EDGES		DO NOT SCALE DRAWING		REVISION	
								TITLE: LOWER CONVEYOR BELT			
DRAWN		NAME		SIGNATURE		DATE		MATERIAL: Corrugated Paper		DWG NO. LS10B011L	
CHK'D								WEIGHT: 0.29		SCALE: 1:5	
APPV'D										SHEET 1 OF 1	
MFG										A2	
Q.A											

12 11 10 9 8 7 6 5 4 3 2 1

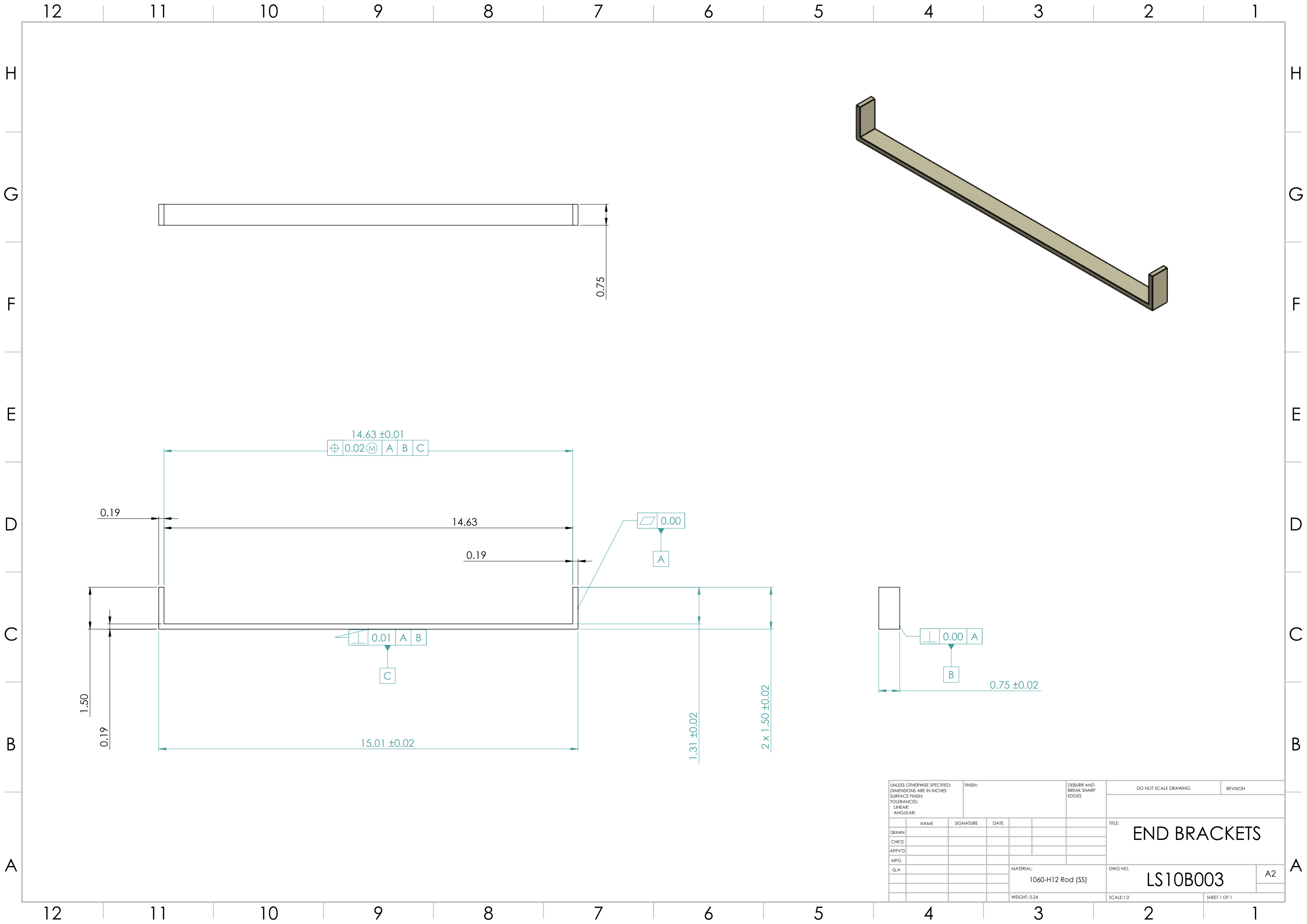

UNLESS OTHERWISE SPECIFIED: DIMENSIONS ARE IN INCHES SURFACE FINISH: TOLERANCES: LINEAR: ANGULAR:			FINISH:			DEBURR AND BREAK SHARP EDGES			DO NOT SCALE DRAWING		REVISION	
DRAWN						TITLE: END BRACKETS						
CHK'D						MATERIAL: 1060-H12 Rod (SS)						
APP'VD						DWG. NO. LS10B003						
MFG						SCALE:1:2						
Q.A.						WEIGHT: 0.24						
						SHEET 1 OF 1						

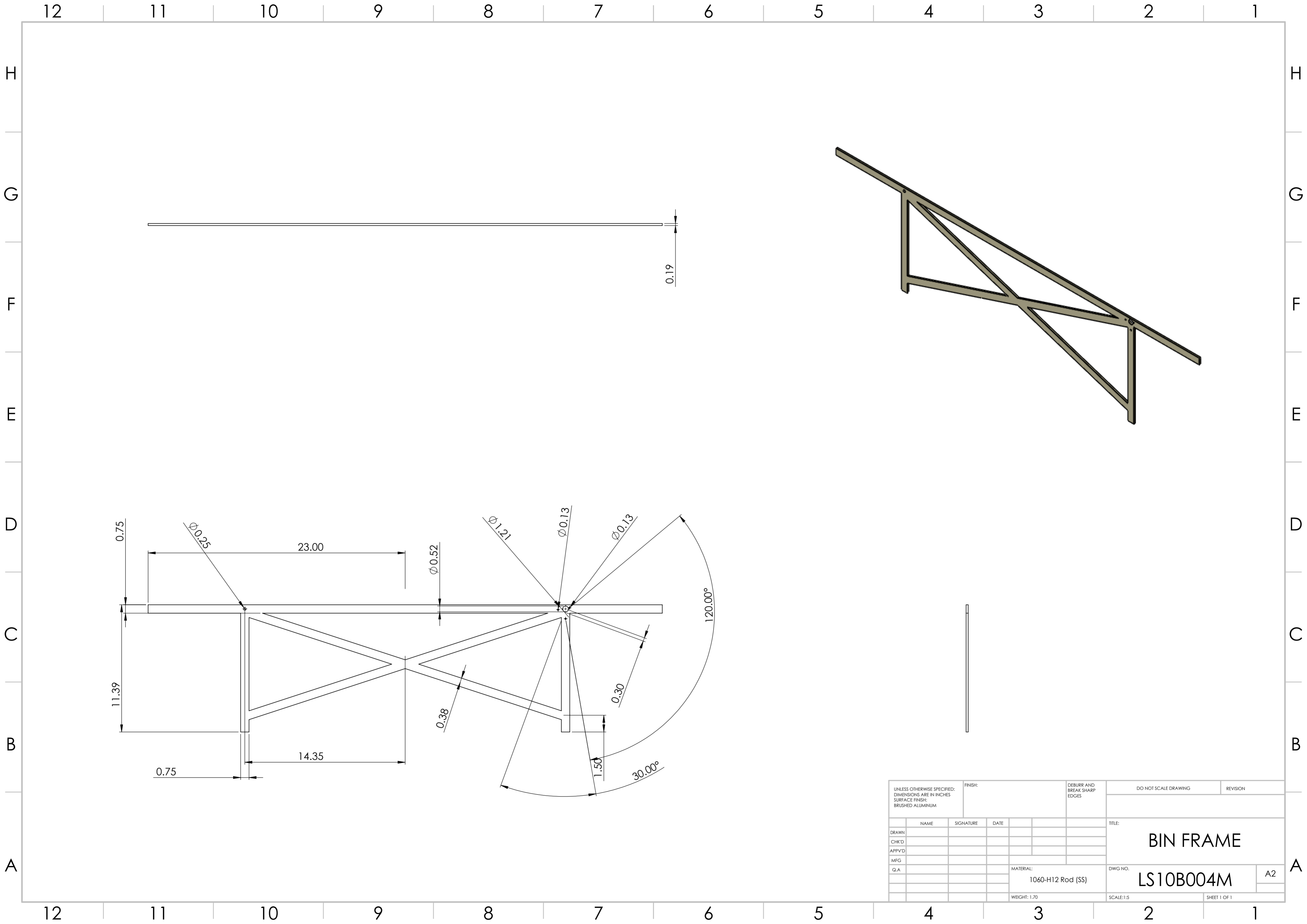

UNLESS OTHERWISE SPECIFIED: DIMENSIONS ARE IN INCHES SURFACE FINISH: BRUSHED ALUMINUM				FINISH:		DEBURR AND BREAK SHARP EDGES		DO NOT SCALE DRAWING		REVISION	
								TITLE: BIN FRAME			
DRAWN				NAME		SIGNATURE		DATE		DWG NO. LS10B004M	
CHK'D										A2	
APPV'D										SCALE:1:5	
MFG										SHEET 1 OF 1	
Q.A								MATERIAL: 1060-H12 Rod (SS)		WEIGHT: 1.70	

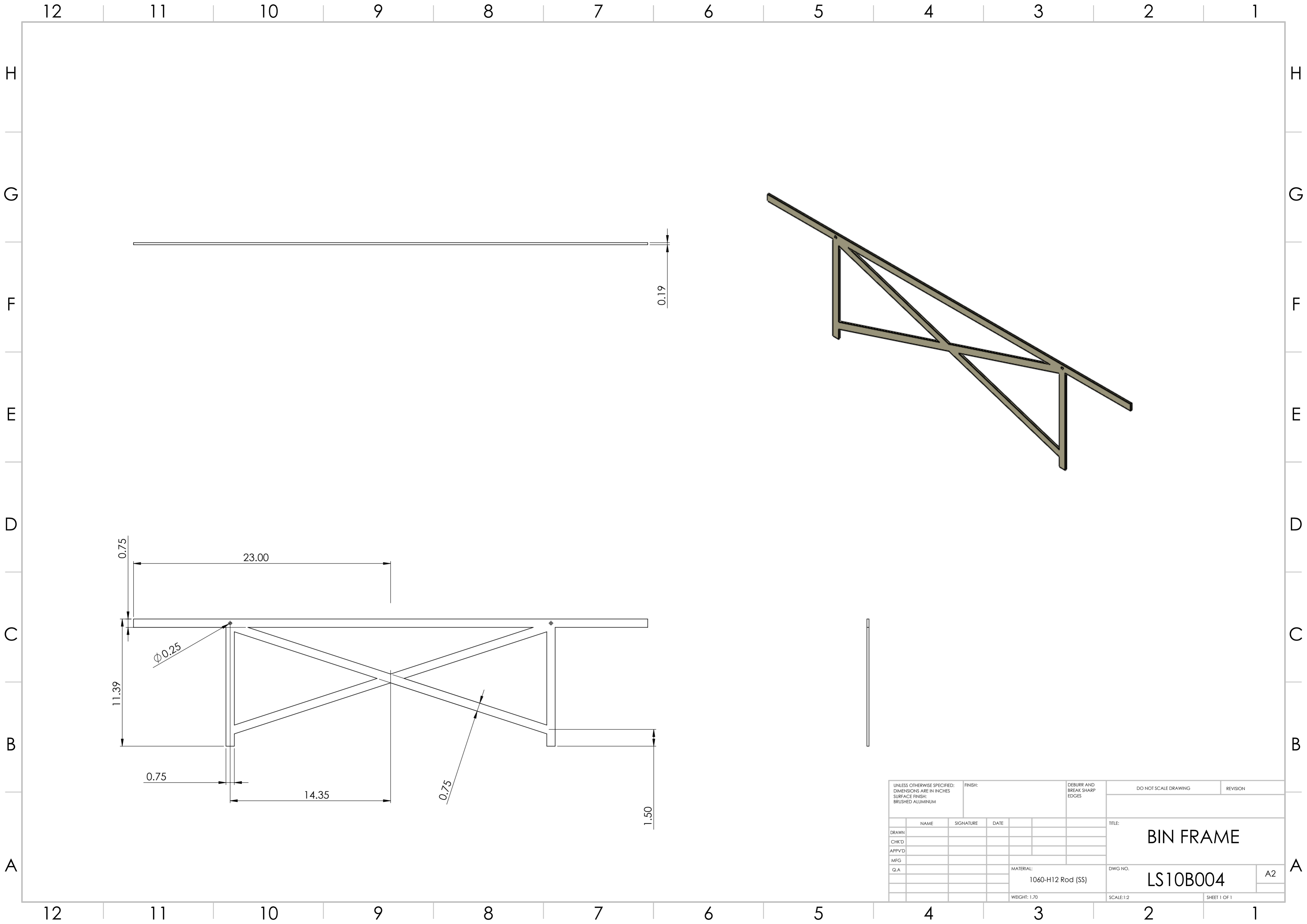

UNLESS OTHERWISE SPECIFIED: DIMENSIONS ARE IN INCHES SURFACE FINISH: BRUSHED ALUMINUM				FINISH:		DEBURR AND BREAK SHARP EDGES		DO NOT SCALE DRAWING		REVISION	
								TITLE: BIN FRAME			
								MATERIAL: 1060-H12 Rod (SS)		DWG NO. LS10B004	
								WEIGHT: 1.70		SCALE:1:2	
								SHEET 1 OF 1			
DRAWN		NAME		SIGNATURE		DATE					
CHK'D											
APPV'D											
MFG											
Q.A											

12 11 10 9 8 7 6 5 4 3 2 1

H
G
F
E
D
C
B
A

H
G
F
E
D
C
B
A

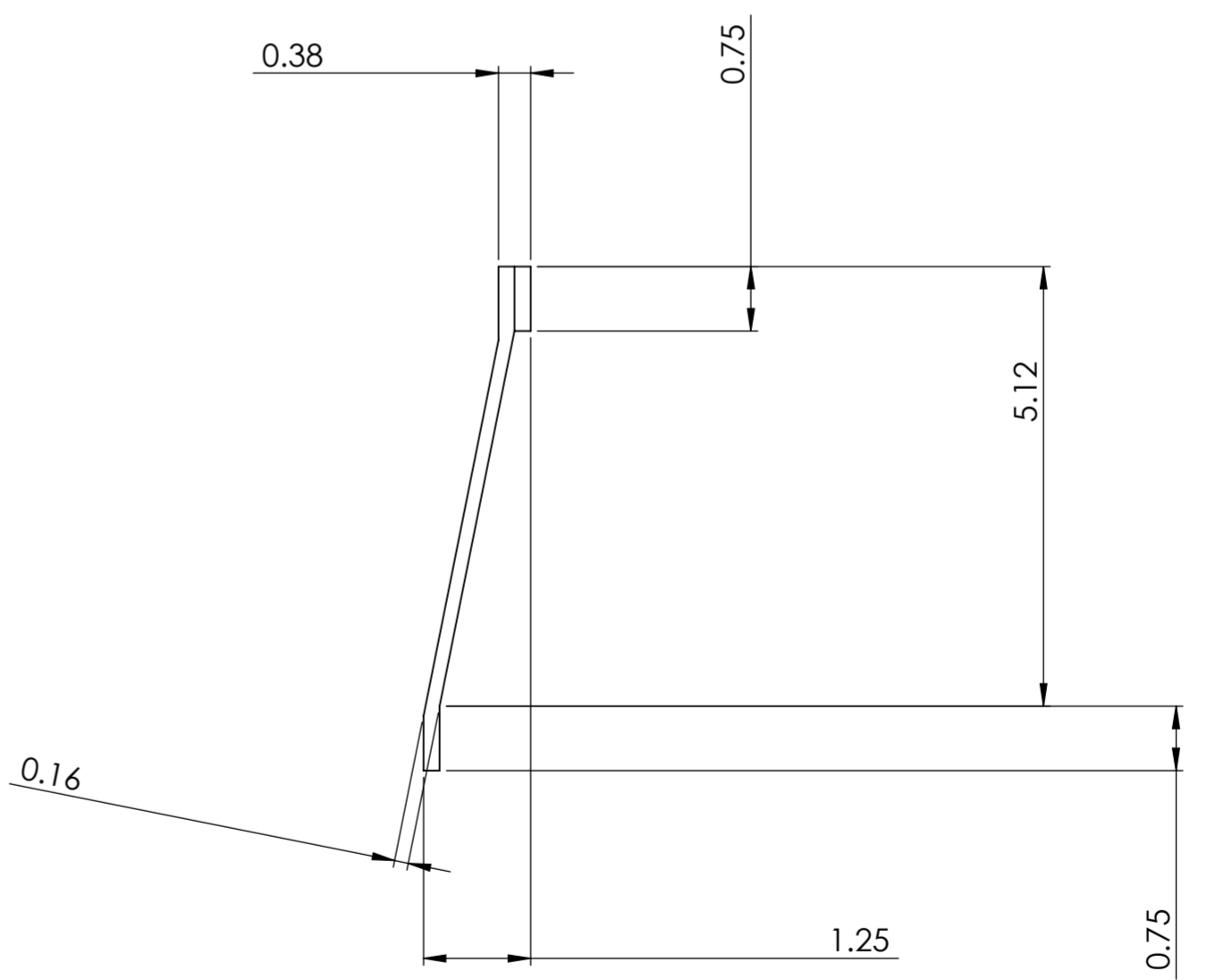
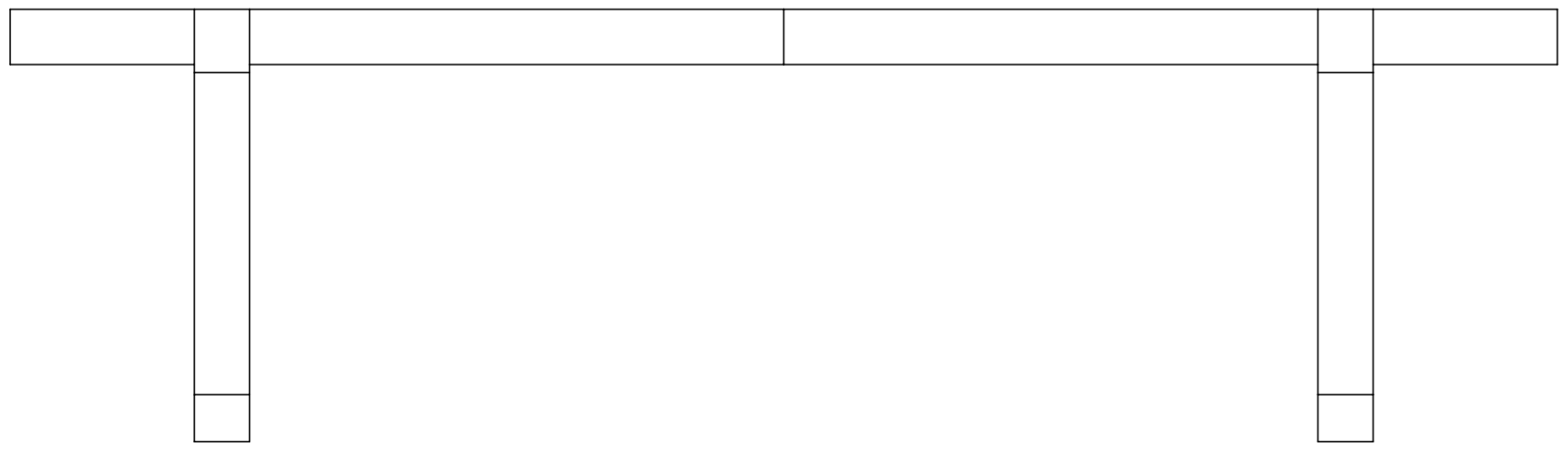
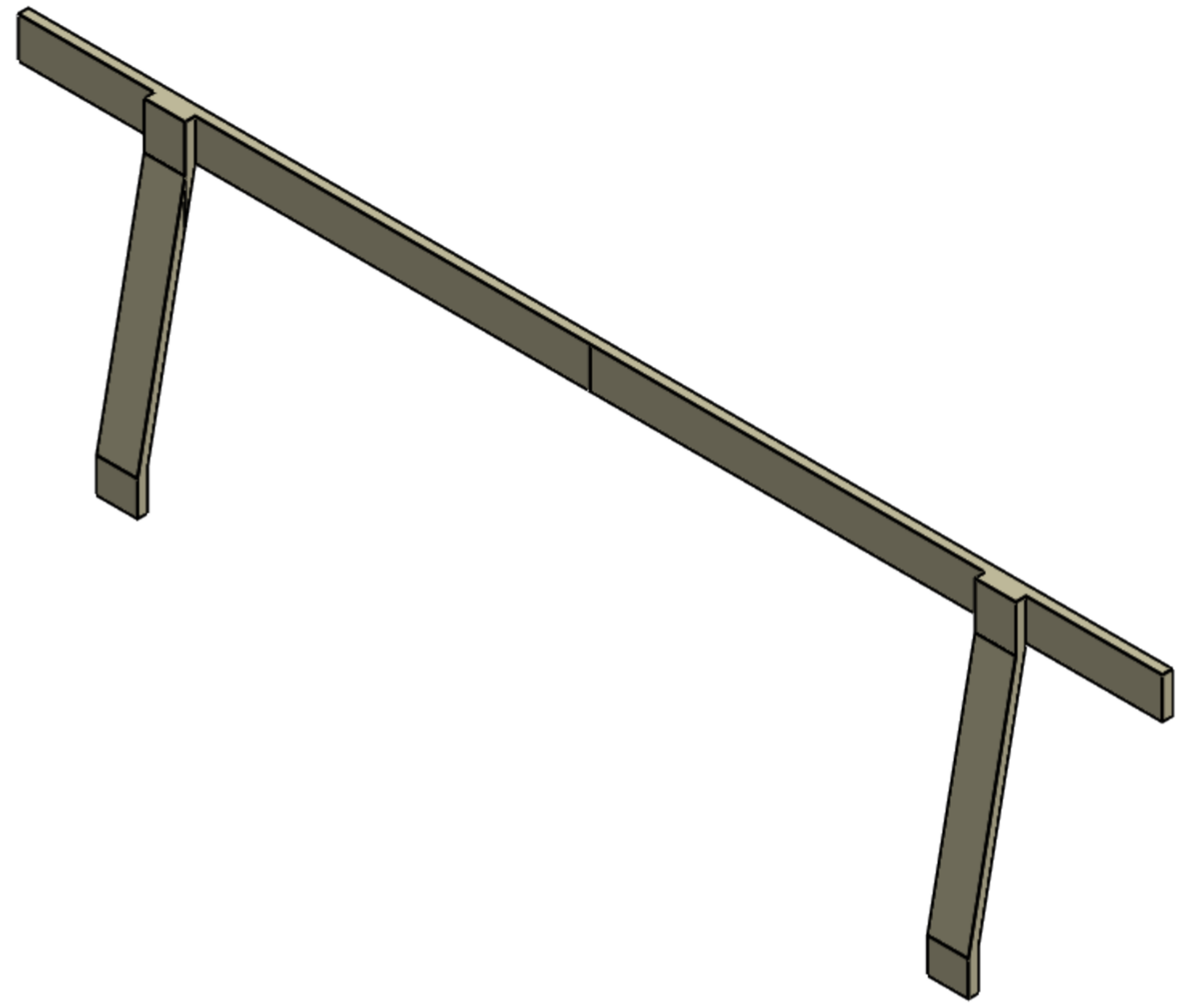
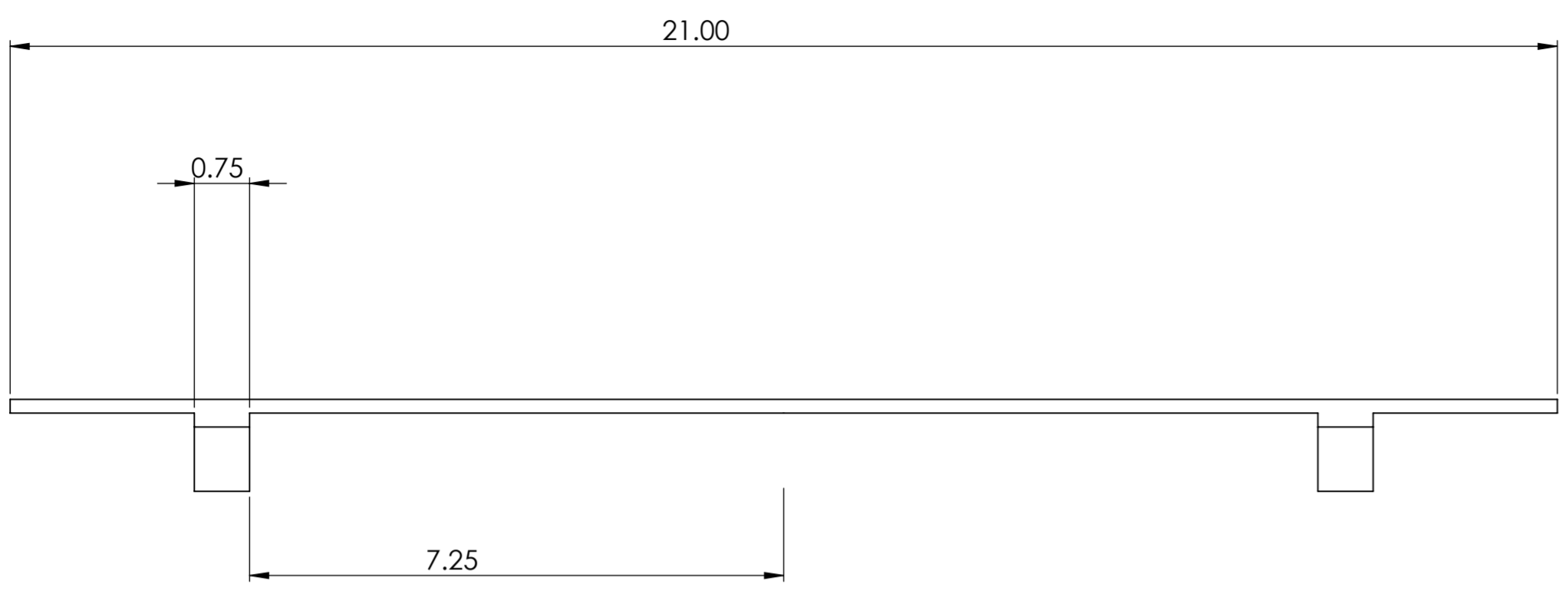

UNLESS OTHERWISE SPECIFIED: DIMENSIONS ARE IN INCHES SURFACE FINISH: BRUSHED ALUMINUM			FINISH:		DEBURR AND BREAK SHARP EDGES		DO NOT SCALE DRAWING		REVISION		
							TITLE: BIN GUIDE				
							MATERIAL: 1060-H12 Rod (SS)		DWG. NO. CS10B005		A2
							WEIGHT: 0.10		SCALE: 1:2		SHEET 1 OF 1
DRAWN	NAME	SIGNATURE	DATE								
CHK'D											
APPV'D											
MFG											
Q.A											

12 11 10 9 8 7 6 5 4 3 2 1

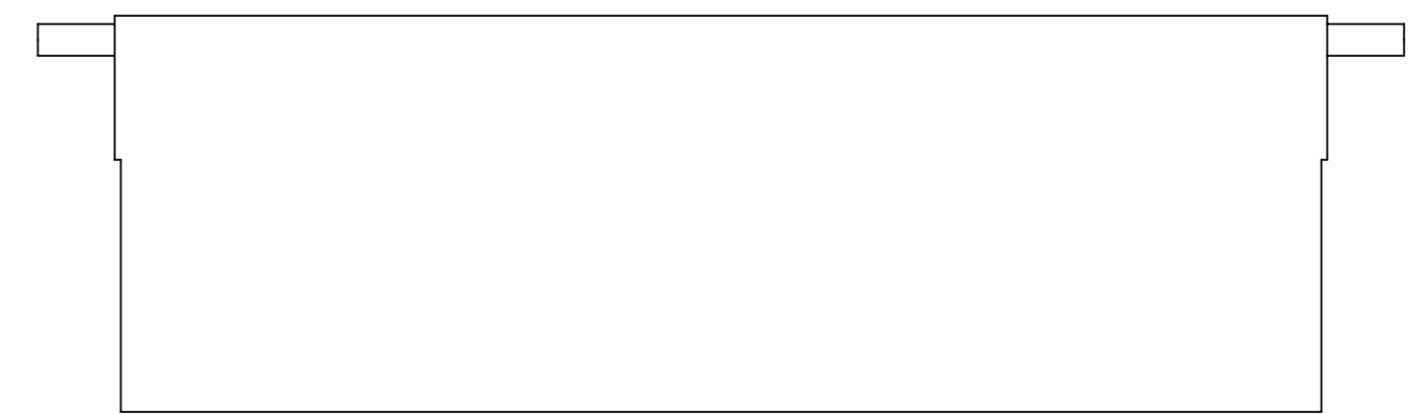
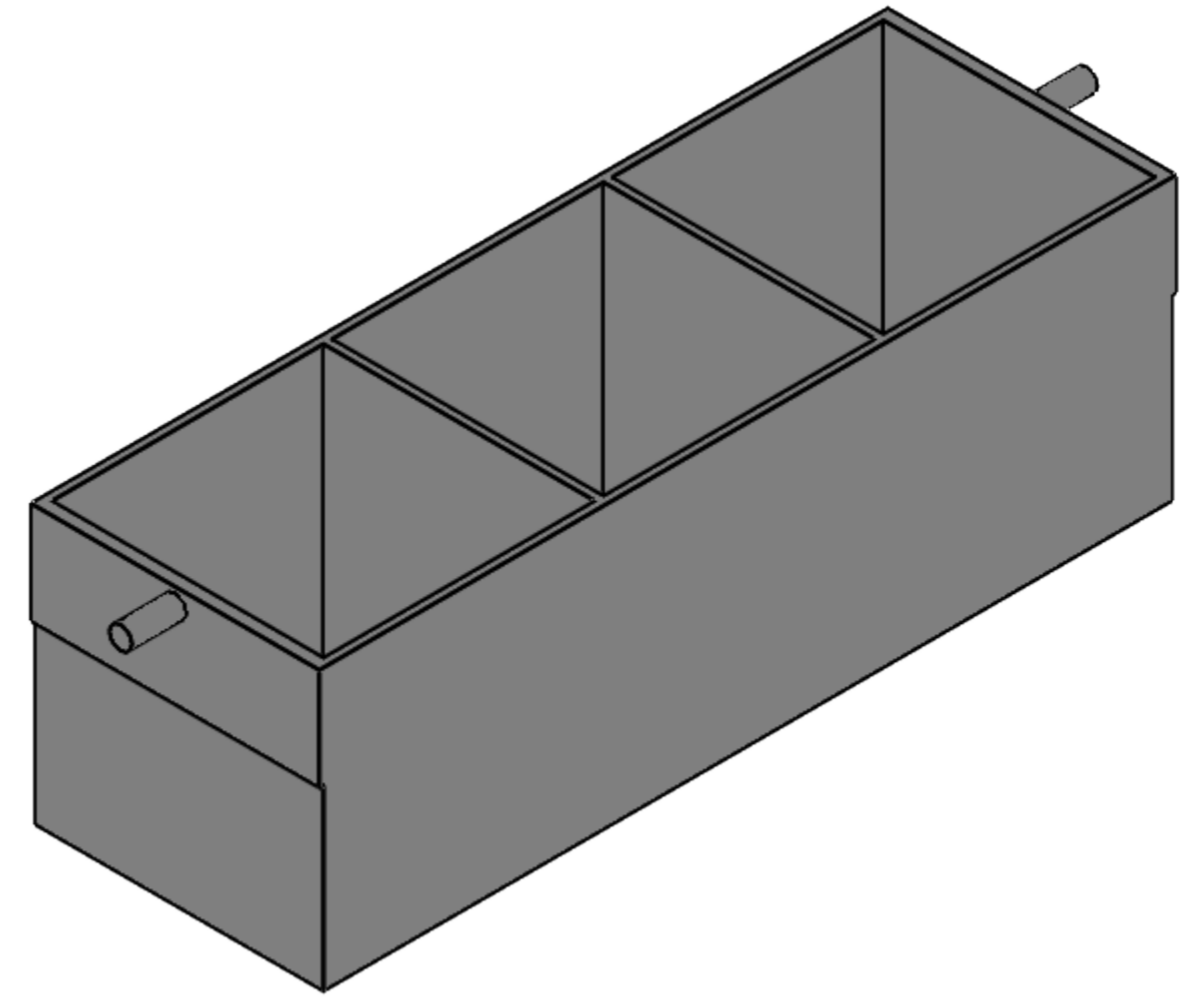
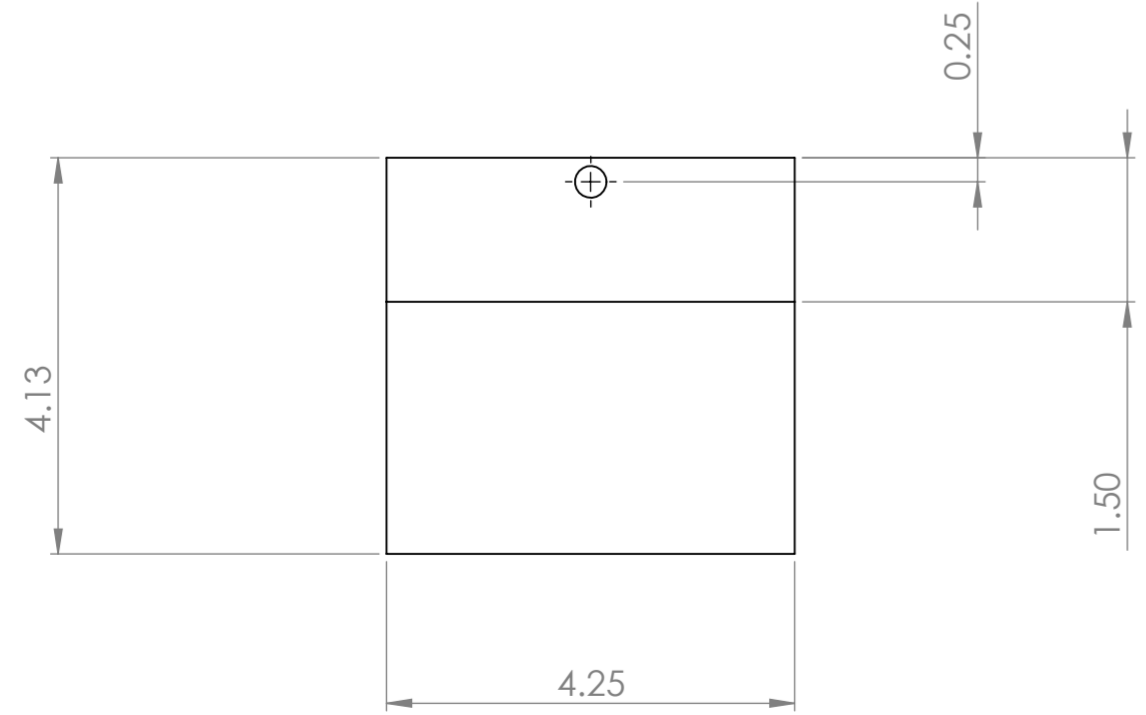
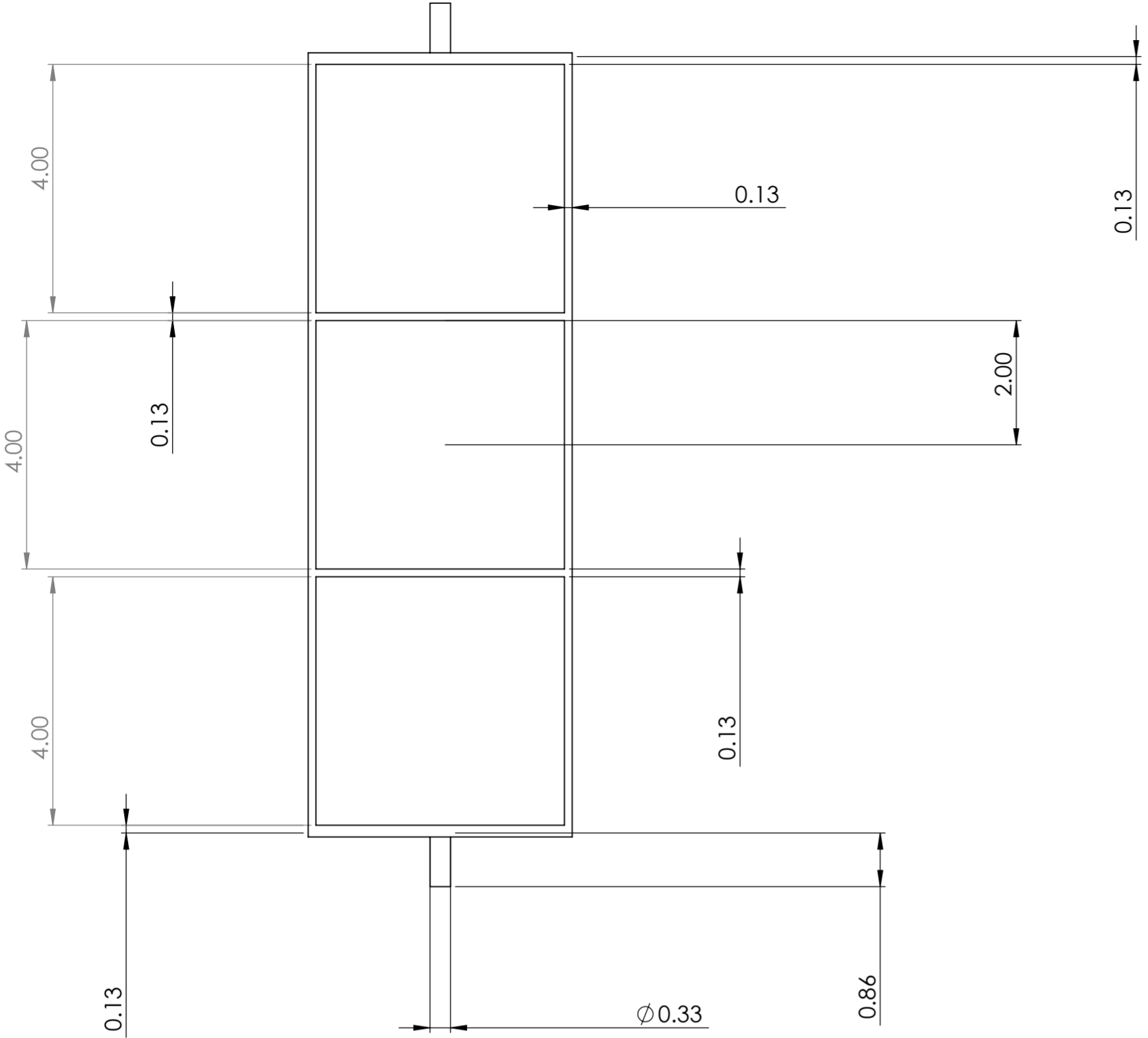
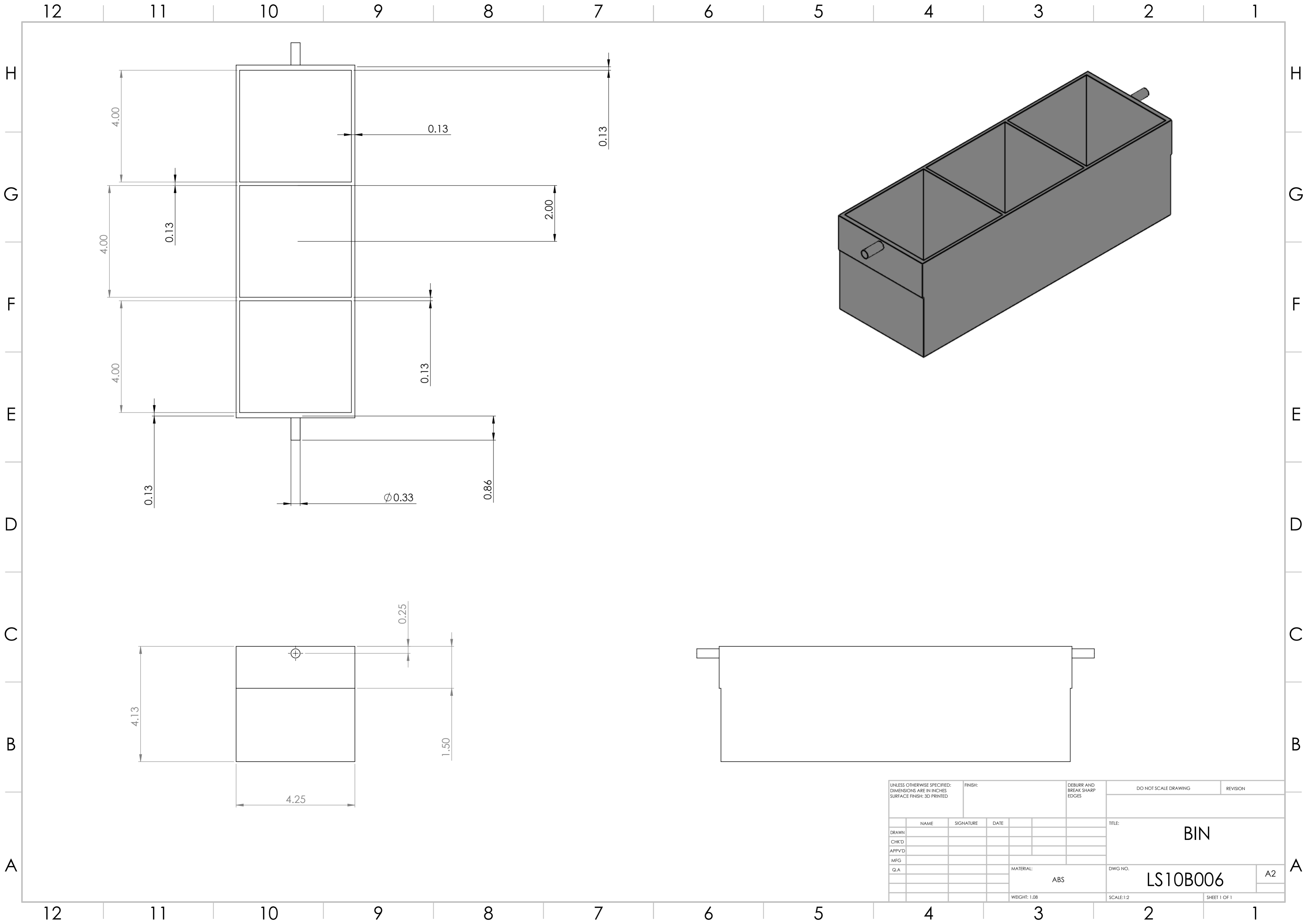

UNLESS OTHERWISE SPECIFIED: DIMENSIONS ARE IN INCHES SURFACE FINISH: 3D PRINTED				FINISH:		DEBURR AND BREAK SHARP EDGES		DO NOT SCALE DRAWING		REVISION	
								TITLE: BIN			
DRAWN				NAME		SIGNATURE		DATE		DWG. NO. LS10B006	
CHK'D										A2	
APPV'D										SCALE:1:2	
MFG										SHEET 1 OF 1	
Q.A.								MATERIAL: ABS		WEIGHT: 1.08	

12 11 10 9 8 7 6 5 4 3 2 1

H
G
F
E
D
C
B
A

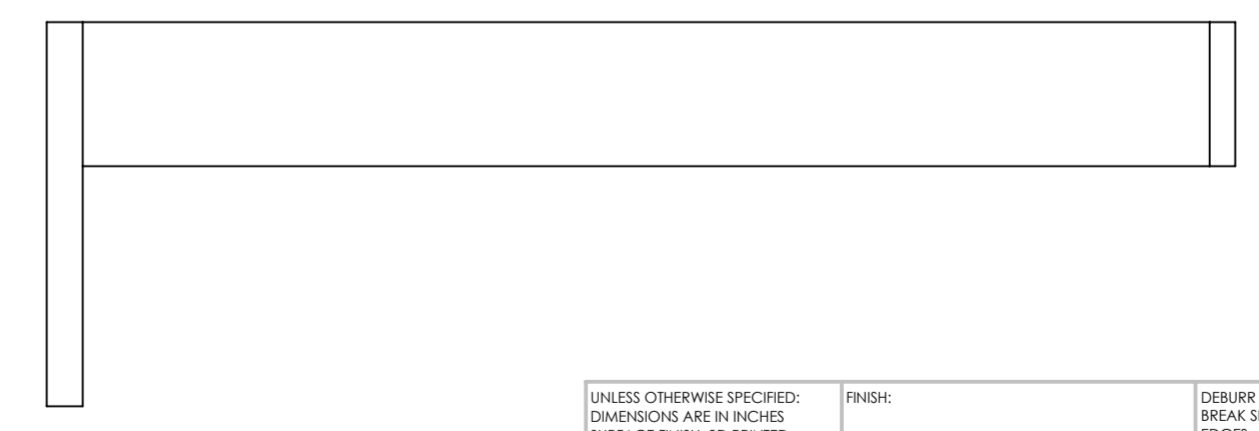
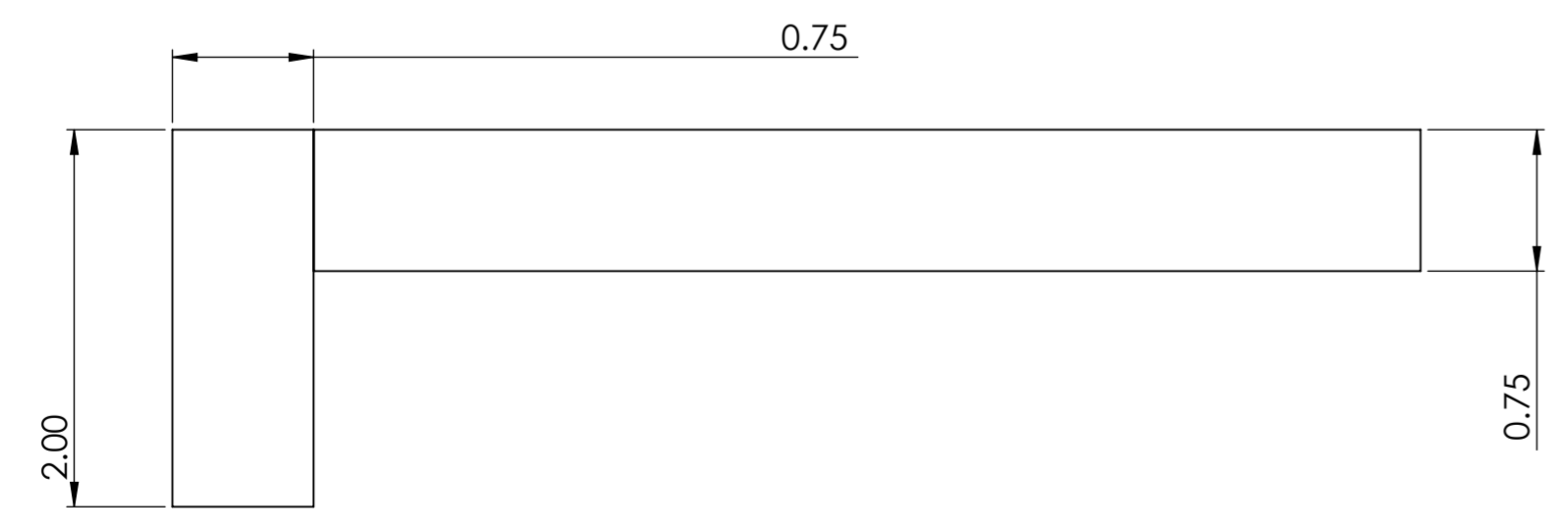
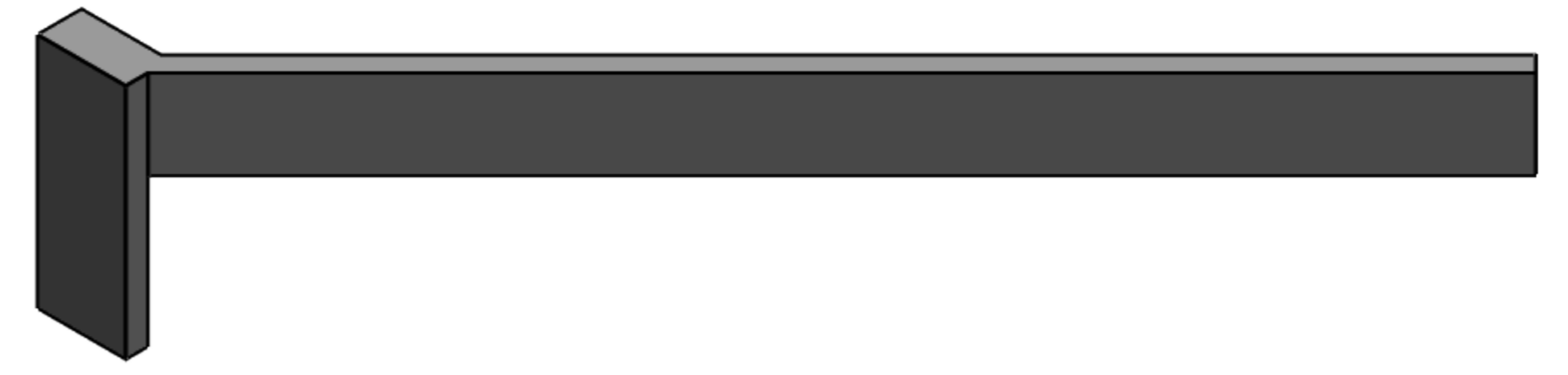
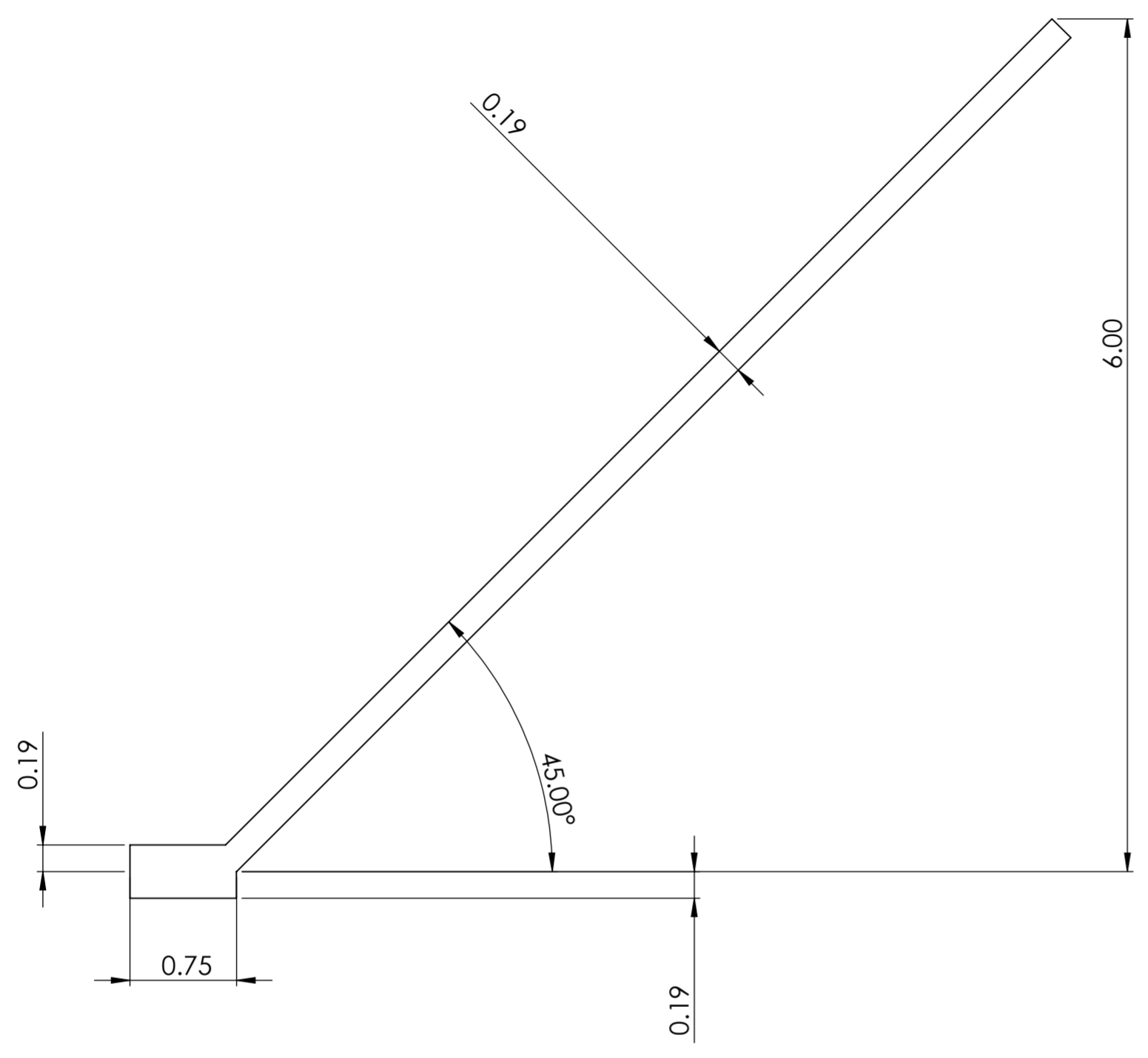

UNLESS OTHERWISE SPECIFIED: DIMENSIONS ARE IN INCHES SURFACE FINISH: 3D PRINTED				FINISH:		DEBURR AND BREAK SHARP EDGES		DO NOT SCALE DRAWING		REVISION		
								TITLE: RIGHT BUMPER				
								MATERIAL: ABS		DWG NO. LS10B008R		A2
								WEIGHT: 0.06		SCALE: 1:1		SHEET 1 OF 1
DRAWN	NAME	SIGNATURE	DATE									
CHK'D												
APPV'D												
MFG												
Q.A												

12 11 10 9 8 7 6 5 4 3 2 1

12 11 10 9 8 7 6 5 4 3 2 1

H
G
F
E
D
C
B
A

H
G
F
E
D
C
B
A

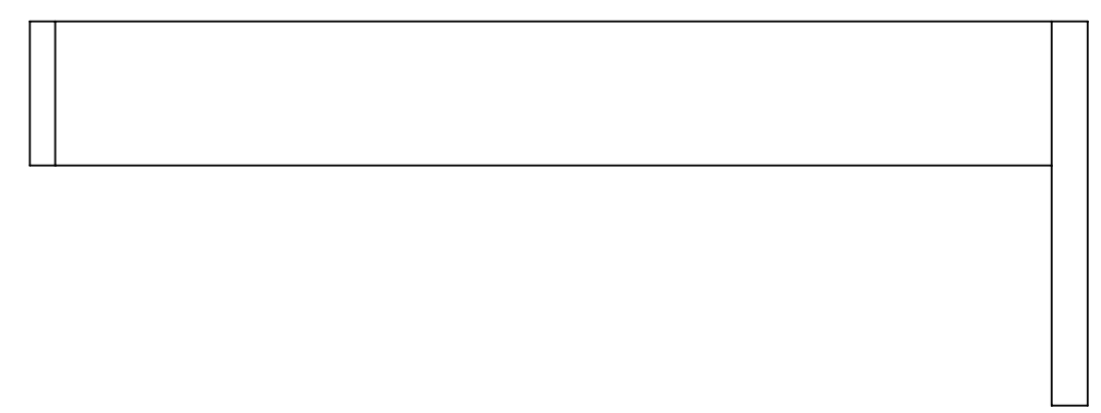
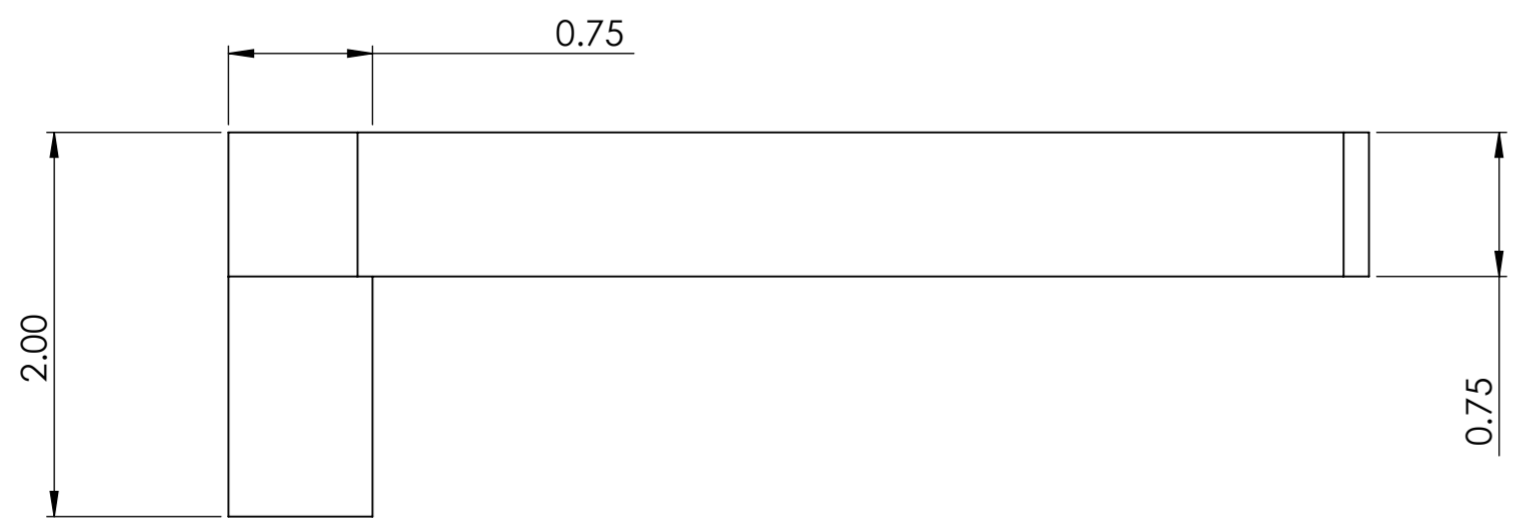
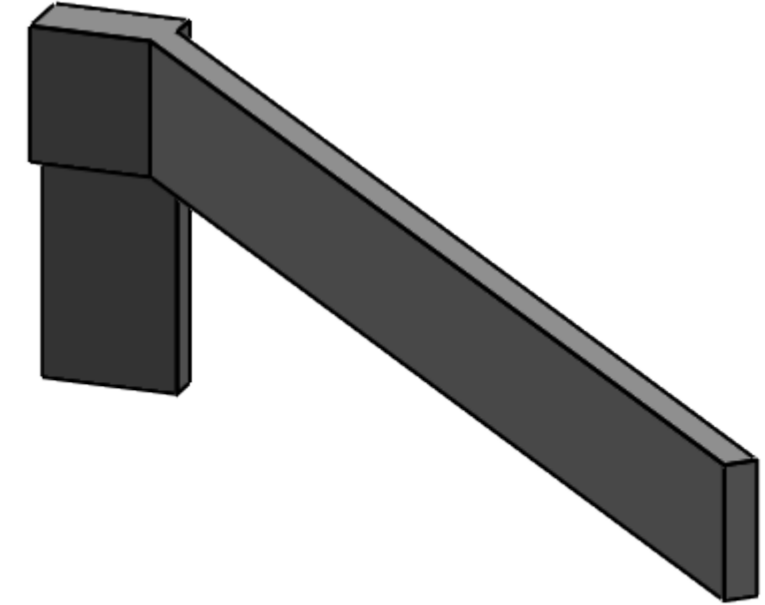
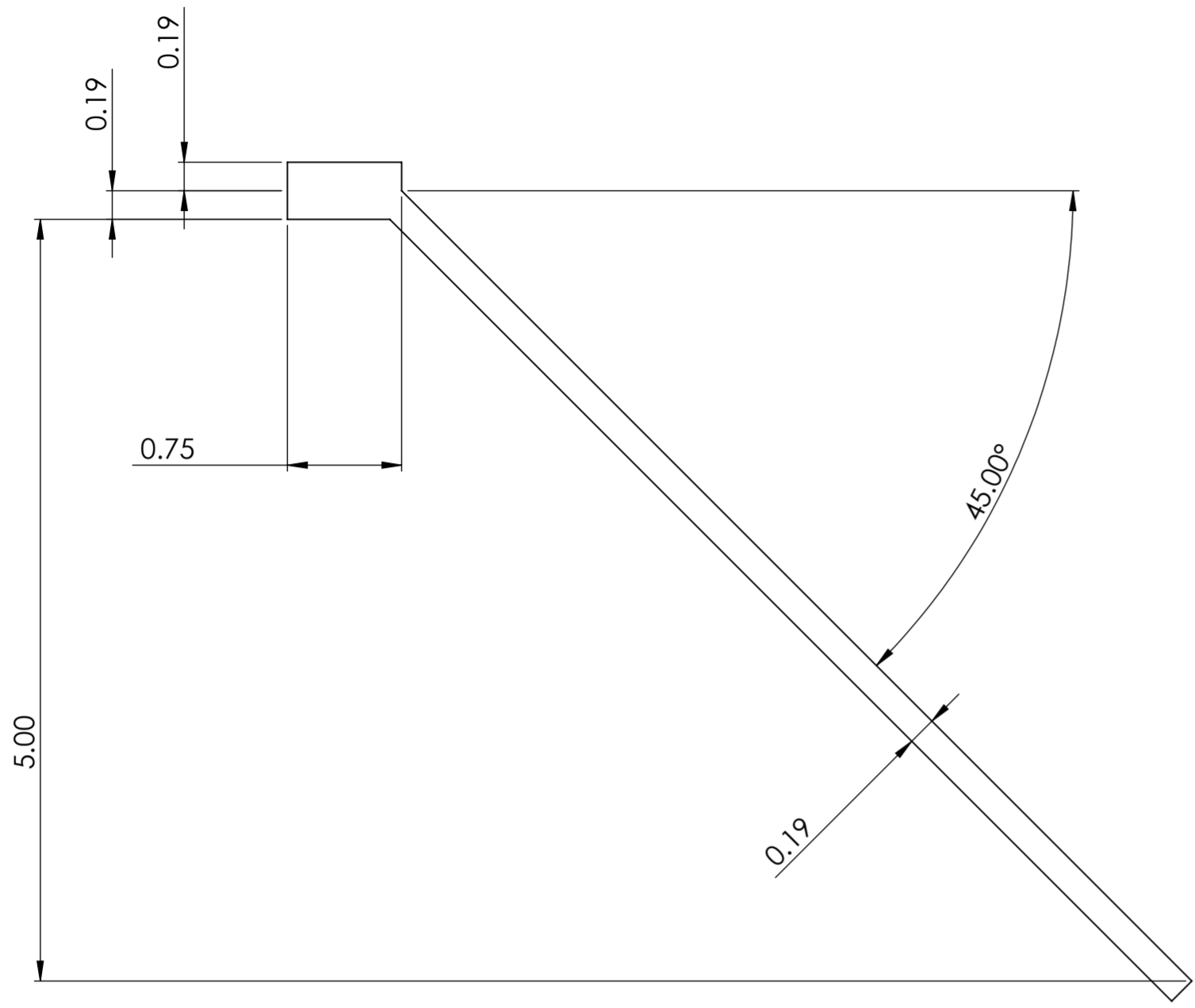

UNLESS OTHERWISE SPECIFIED: DIMENSIONS ARE IN INCHES SURFACE FINISH: 3D PRINTED				FINISH:		DEBURR AND BREAK SHARP EDGES		DO NOT SCALE DRAWING		REVISION		
								TITLE: LEFT BUMPER				
								MATERIAL: ABS		DWG NO. LS10B008L		A2
								WEIGHT: 0.05		SCALE: 1:1		SHEET 1 OF 1
DRAWN	NAME	SIGNATURE	DATE									
CHK'D												
APPV'D												
MFG												
Q.A												

12 11 10 9 8 7 6 5 4 3 2 1

12 11 10 9 8 7 6 5 4 3 2 1

H
G
F
E
D
C
B
A

H
G
F
E
D
C
B
A

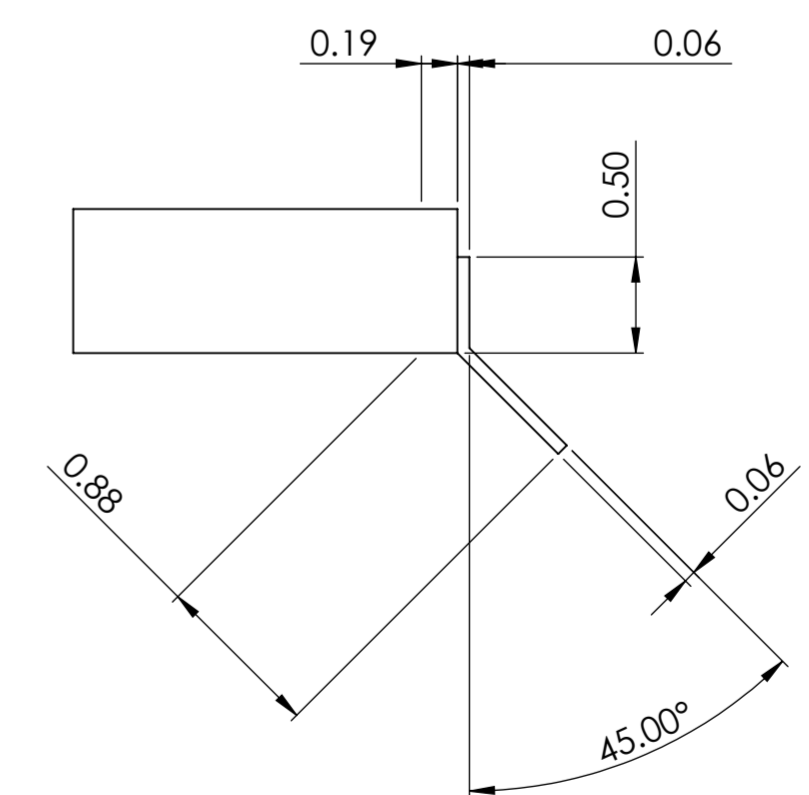
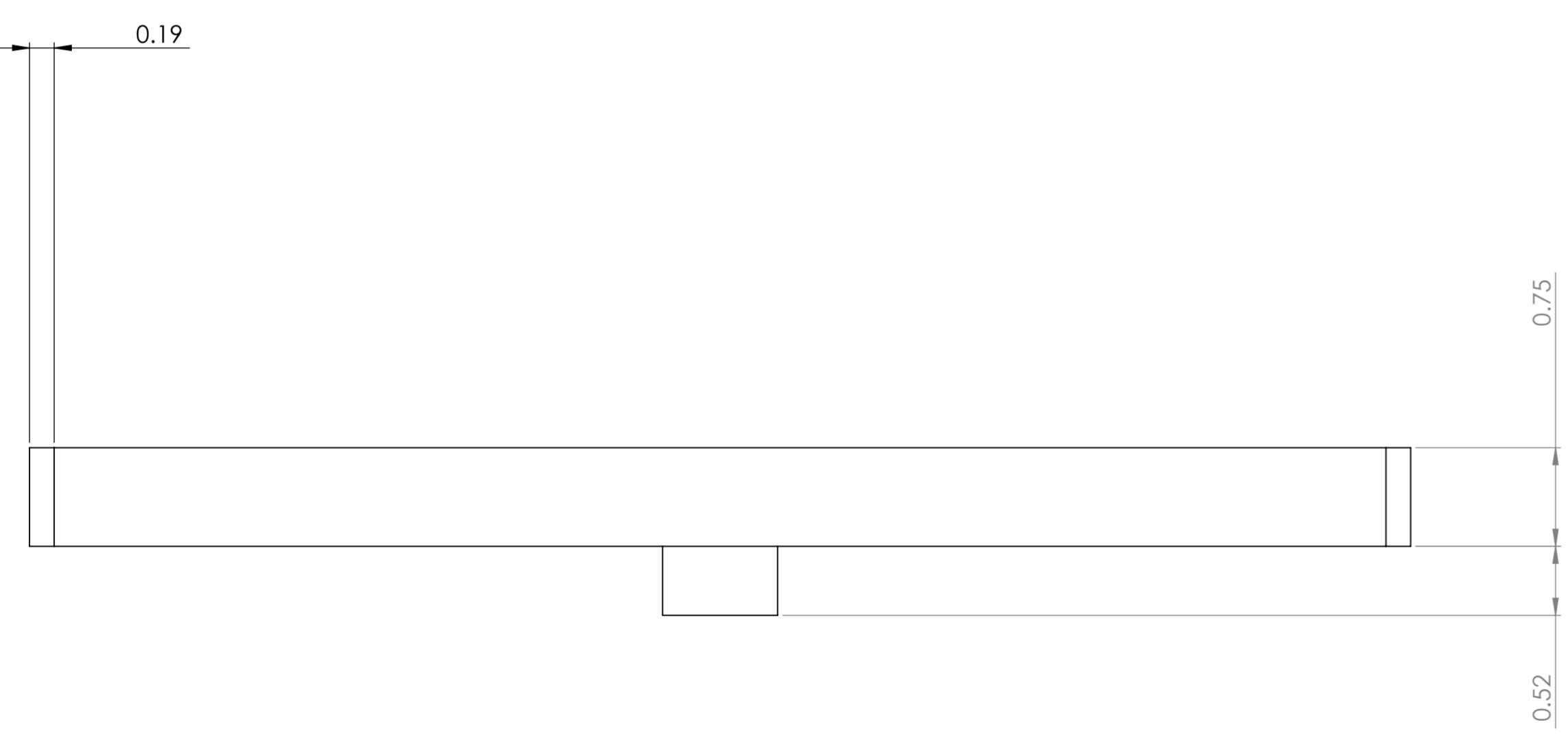
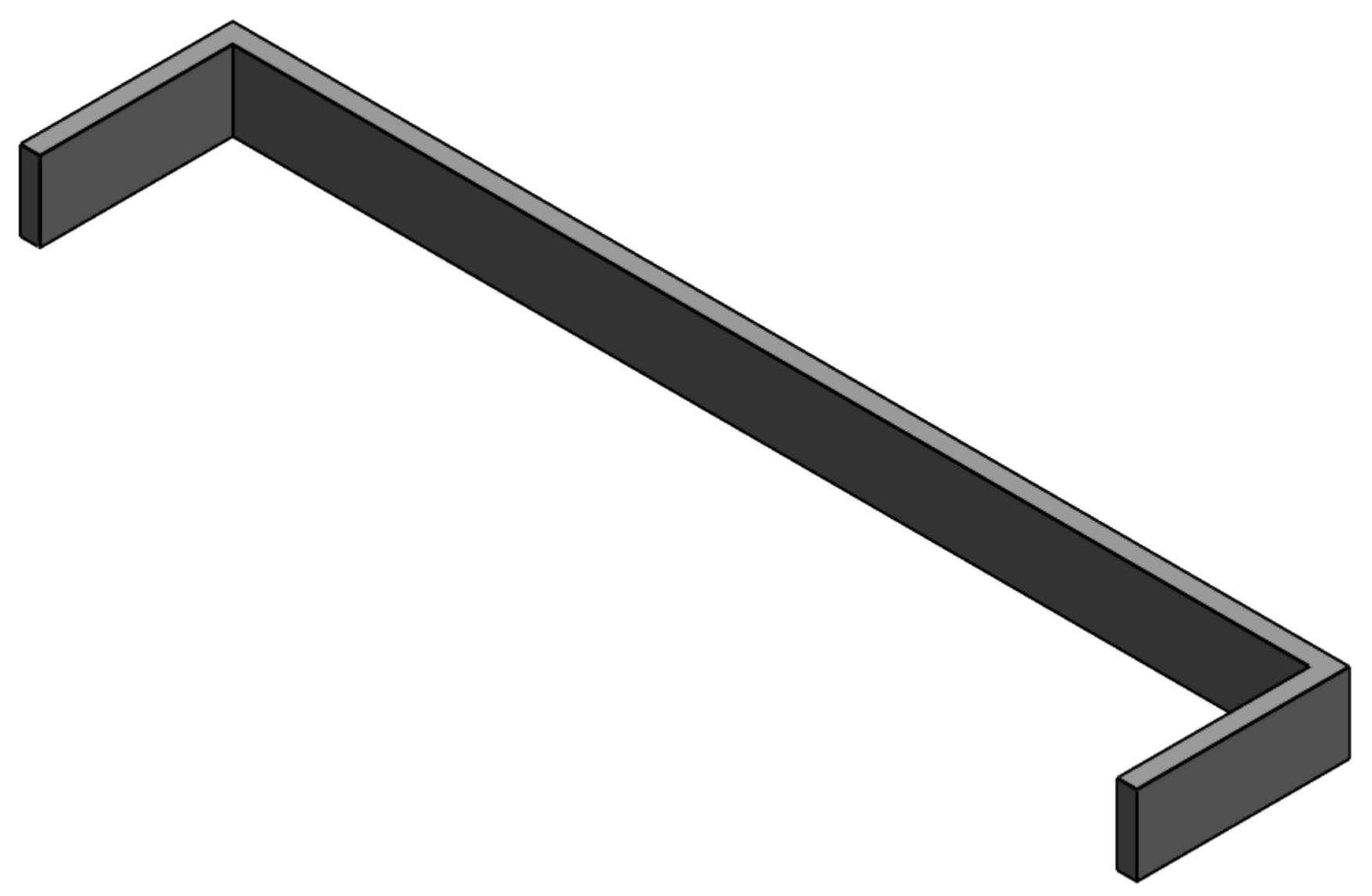
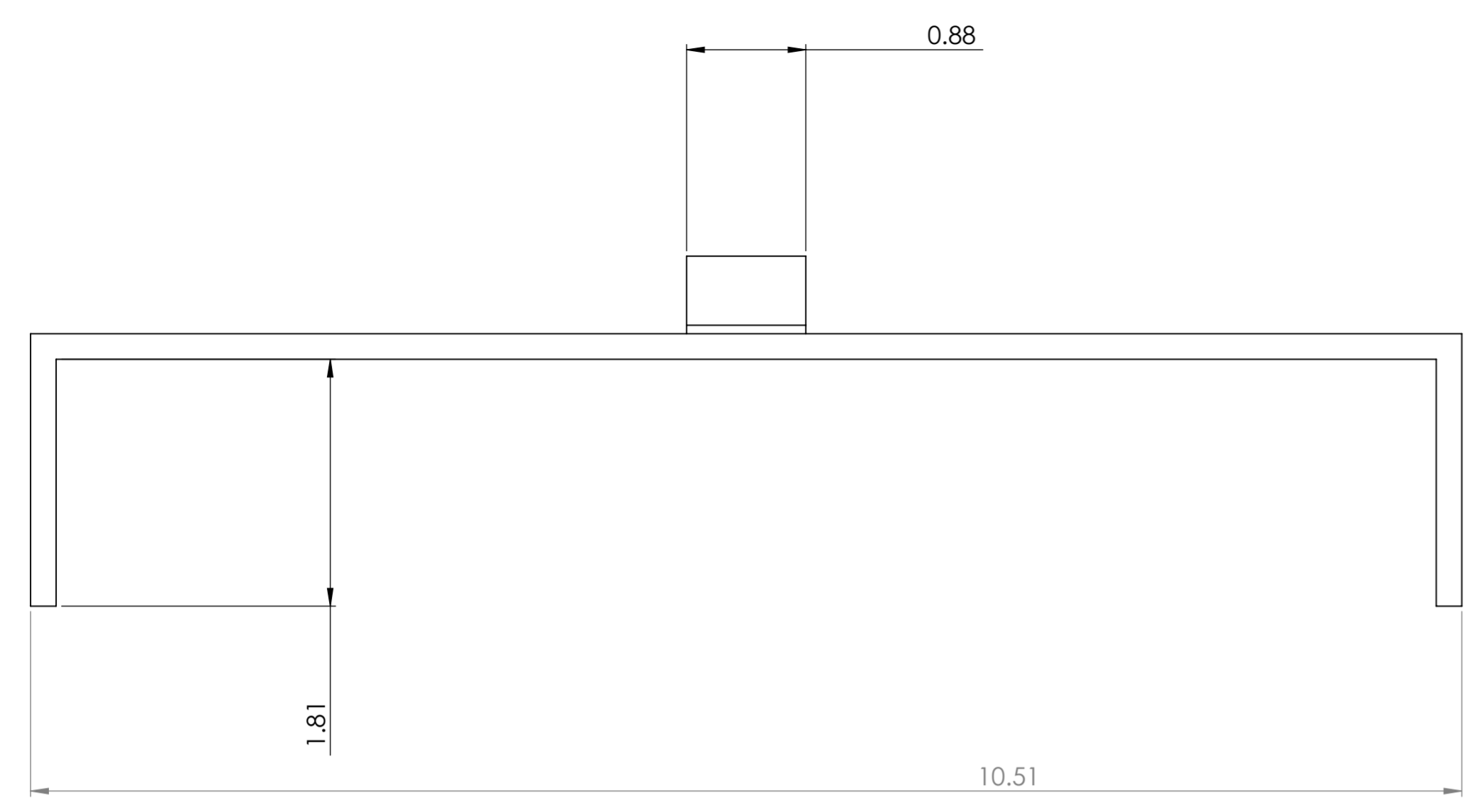

UNLESS OTHERWISE SPECIFIED: DIMENSIONS ARE IN INCHES SURFACE FINISH: 3D PRINTED				FINISH:		DEBURR AND BREAK SHARP EDGES		DO NOT SCALE DRAWING		REVISION	
DRAWN				NAME		SIGNATURE		DATE		TITLE: CAMERA BRACKET	
CHK'D										DWG NO. LS10B009	
APPV'D										A2	
MFG										SCALE:1:1	
Q.A.								MATERIAL: ABS		SHEET 1 OF 1	
								WEIGHT: 0.08			

12 11 10 9 8 7 6 5 4 3 2 1

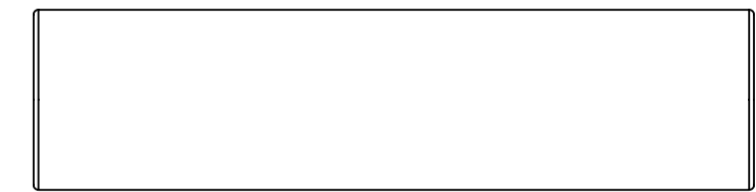
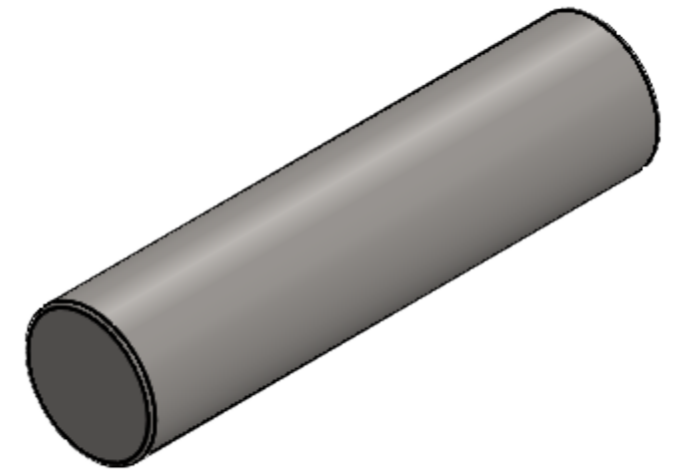
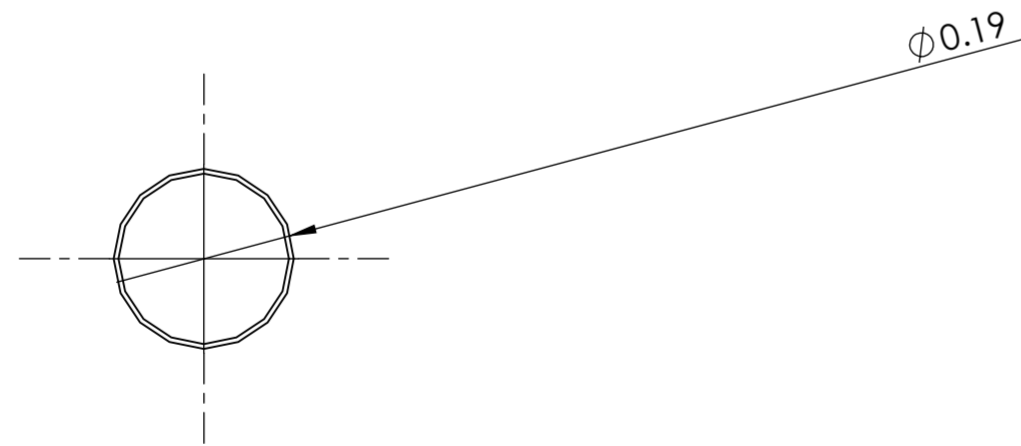
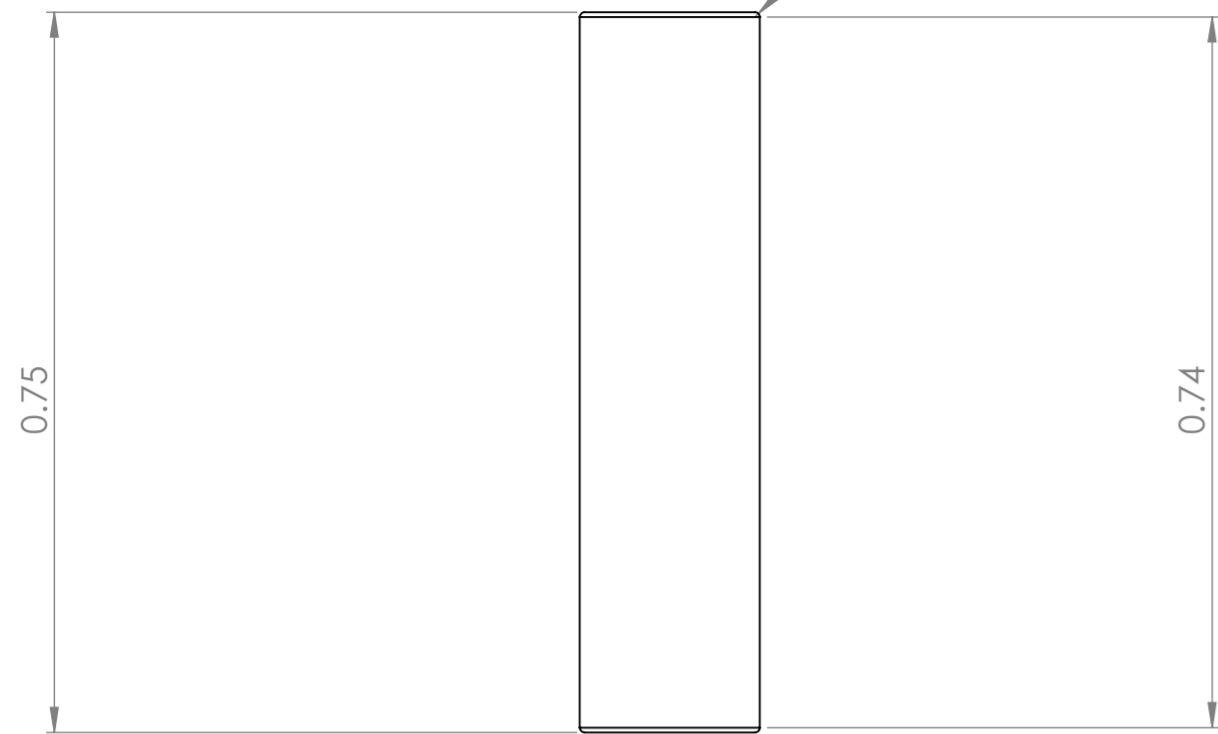
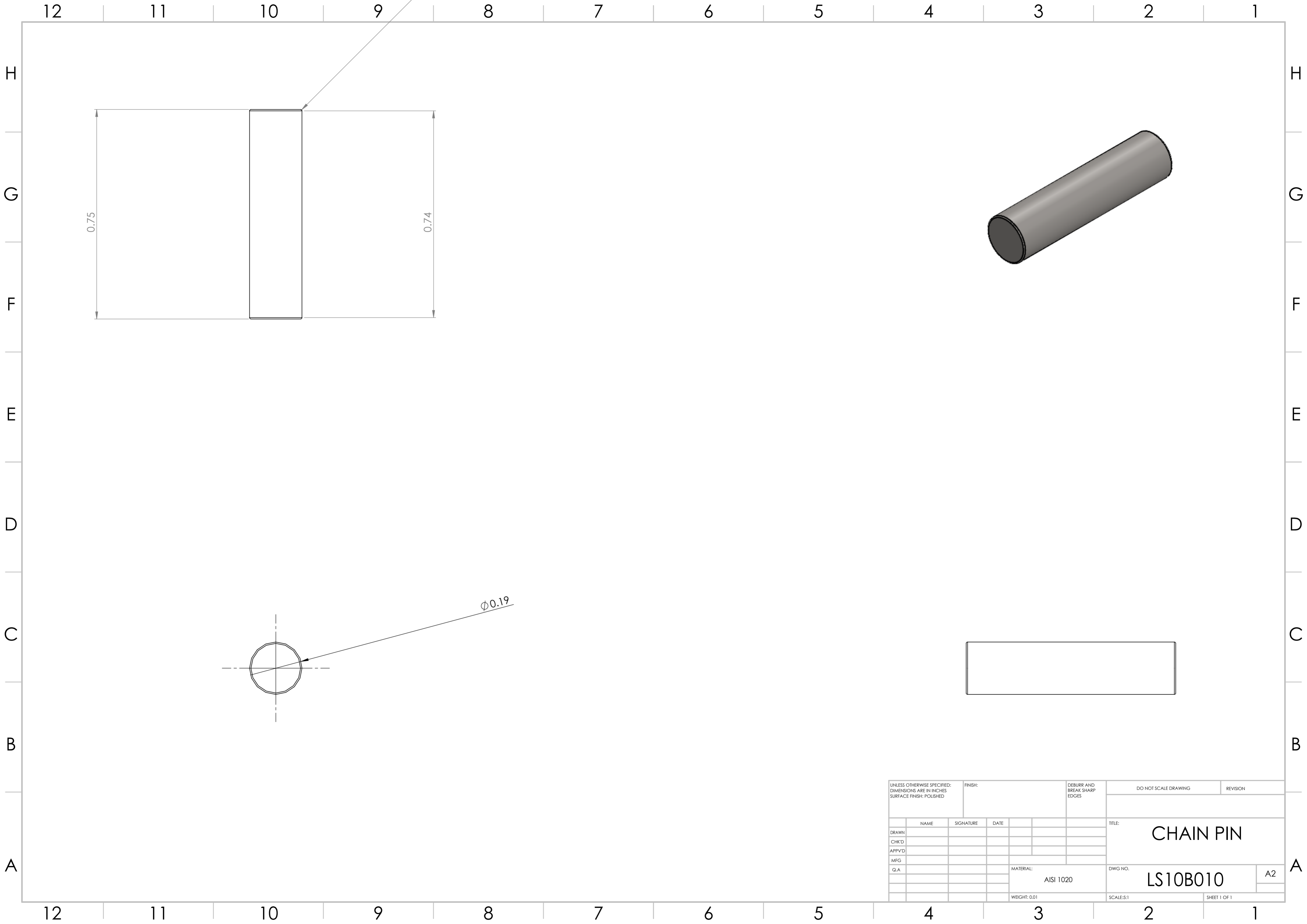

UNLESS OTHERWISE SPECIFIED: DIMENSIONS ARE IN INCHES SURFACE FINISH: POLISHED			FINISH:			DEBURR AND BREAK SHARP EDGES			DO NOT SCALE DRAWING		REVISION	
DRAWN						TITLE: CHAIN PIN						
CHK'D						DWG NO. LS10B010						
APPV'D						SCALE: 1						
MFG						SHEET 1 OF 1						
Q.A.						MATERIAL: AISI 1020			WEIGHT: 0.01			

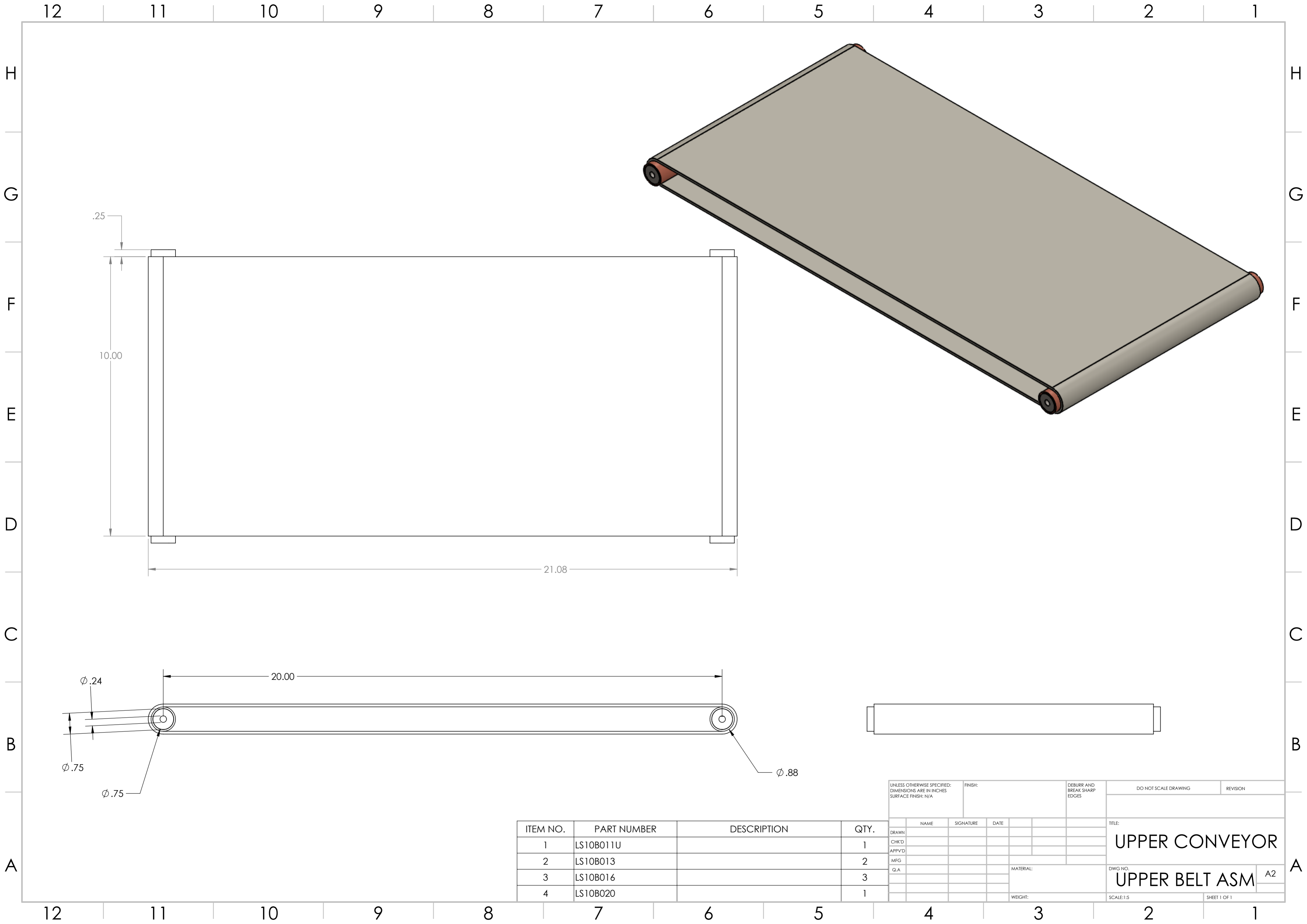

ITEM NO.	PART NUMBER	DESCRIPTION	QTY.
1	LS10B011U		1
2	LS10B013		2
3	LS10B016		3
4	LS10B020		1

UNLESS OTHERWISE SPECIFIED: DIMENSIONS ARE IN INCHES SURFACE FINISH: N/A				FINISH:		DEBURR AND BREAK SHARP EDGES		DO NOT SCALE DRAWING		REVISION	
DRAWN				NAME		SIGNATURE		DATE		TITLE:	
CHK'D										UPPER CONVEYOR	
APPV'D										DWG. NO.	
MFG										UPPER BELT ASM A2	
Q.A.										SCALE:1:5	
						MATERIAL:				SHEET 1 OF 1	
						WEIGHT:					

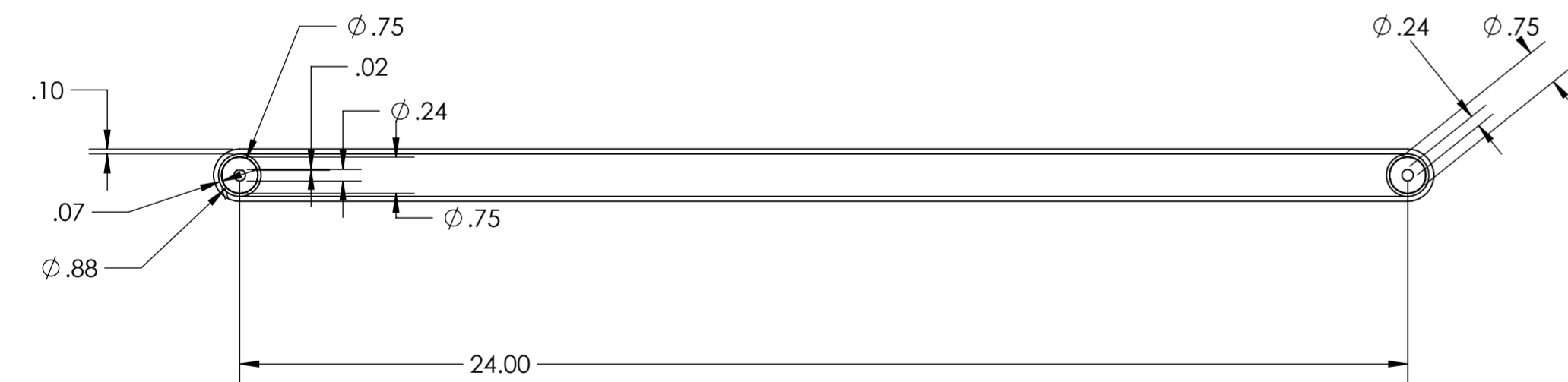
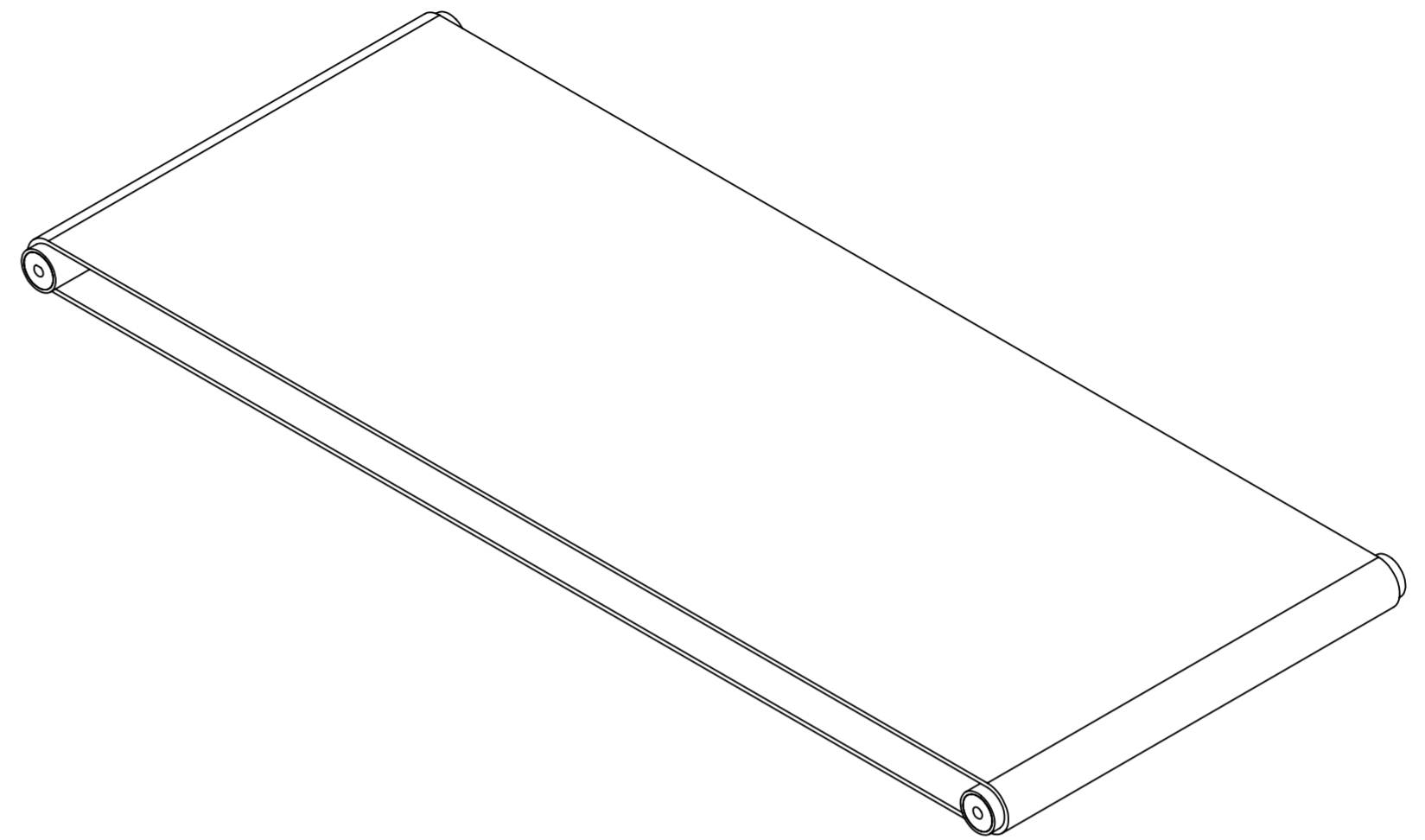

ITEM NO.	PART NUMBER	DESCRIPTION	QTY.
1	LS10B011L		1
2	LS10B016		3
3	LS10B020		1
4	LS10B013		2

UNLESS OTHERWISE SPECIFIED: DIMENSIONS ARE IN MILLIMETERS				FINISH:		DEBURR AND BREAK SHARP EDGES		DO NOT SCALE DRAWING		REVISION
TOLERANCES: LINEAR: ANGULAR:										
DRAWN	NAME	SIGNATURE	DATE					TITLE:		
CHK'D								DWG NO. Conveyor 2 A2		
APP'VD										
MFG										
Q.A.										
						MATERIAL:		SCALE:1:5		SHEET 1 OF 1
						WEIGHT:				

12 11 10 9 8 7 6 5 4 3 2 1

H
G
F
E
D
C
B
A

H
G
F
E
D
C
B
A

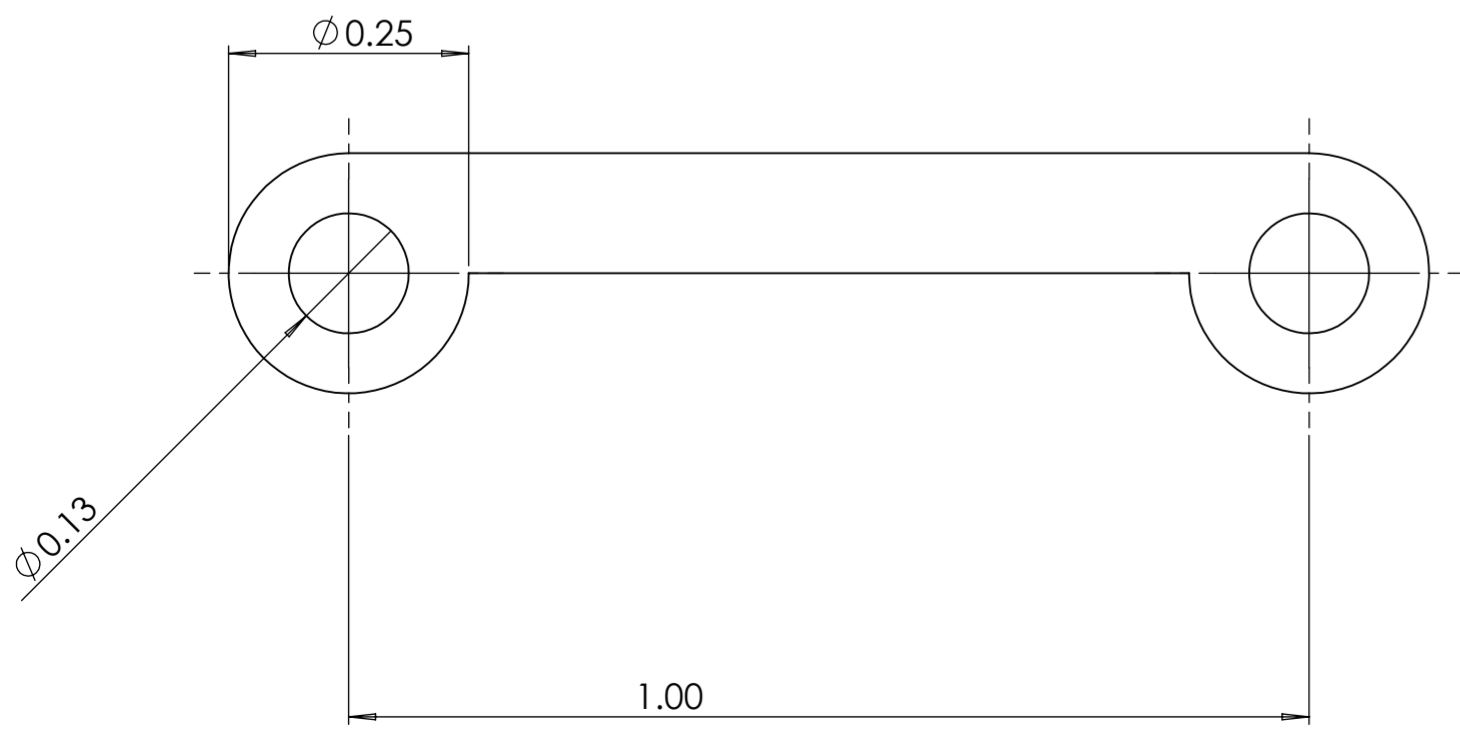
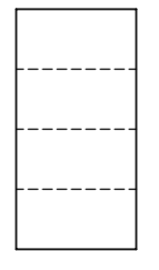
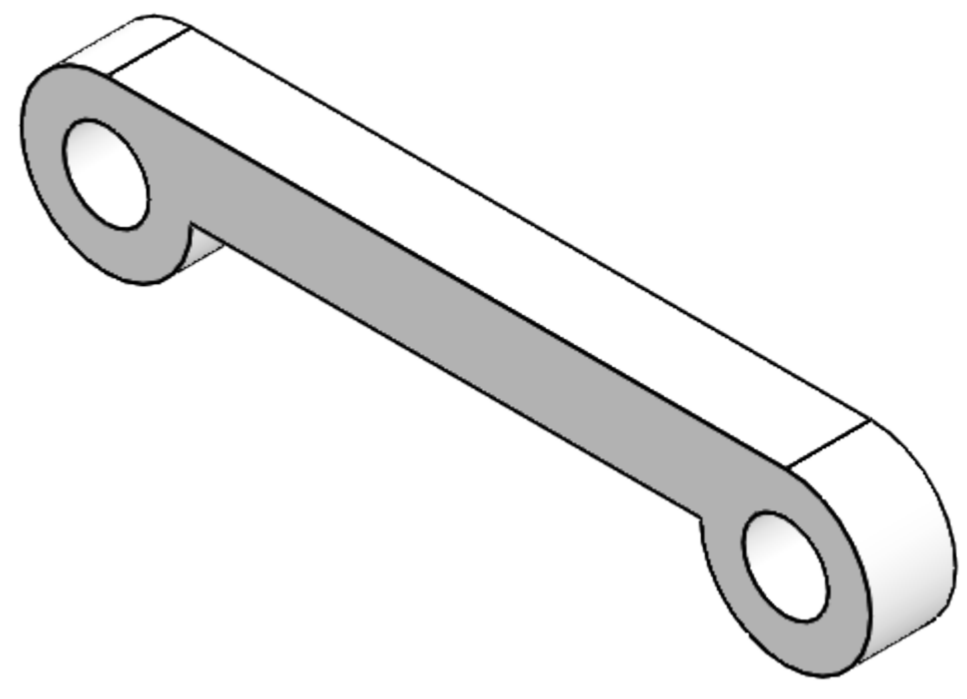
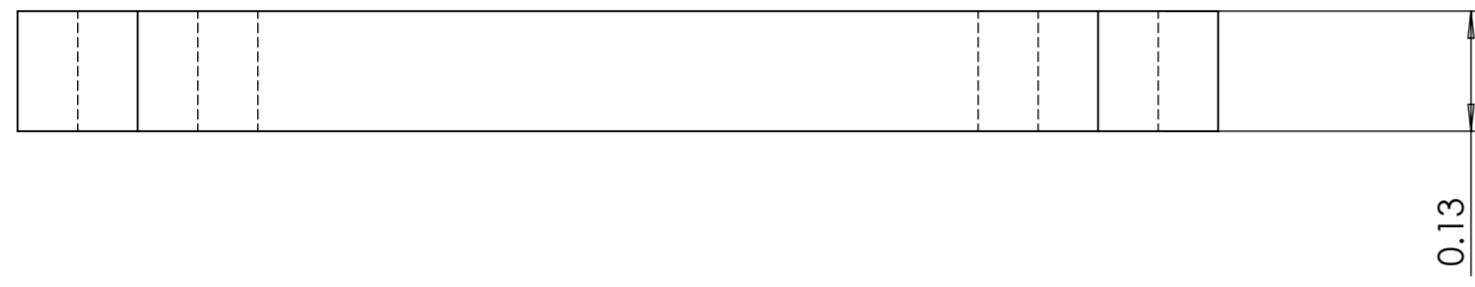

UNLESS OTHERWISE SPECIFIED: DIMENSIONS ARE IN INCHES				FINISH:		DEBURR AND BREAK SHARP EDGES		DO NOT SCALE DRAWING		REVISION	
								TITLE: LIFT CHAIN			
								MATERIAL: ABS		DWG. NO. LS10B018	
								WEIGHT: 0.00		SCALE: S:1	
										SHEET 1 OF 1	
DRAWN	NAME	SIGNATURE	DATE								
CHK'D											
APPV'D											
MFG											
Q.A											

12 11 10 9 8 7 6 5 4 3 2 1

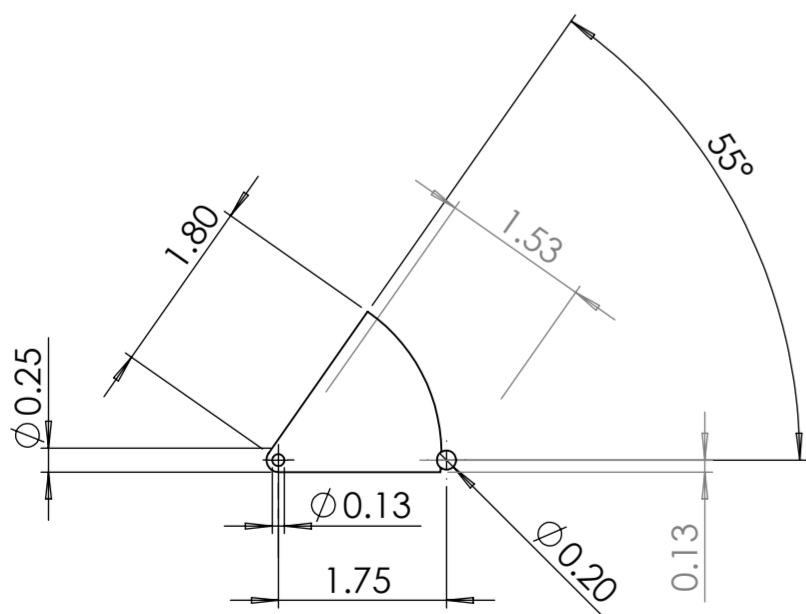
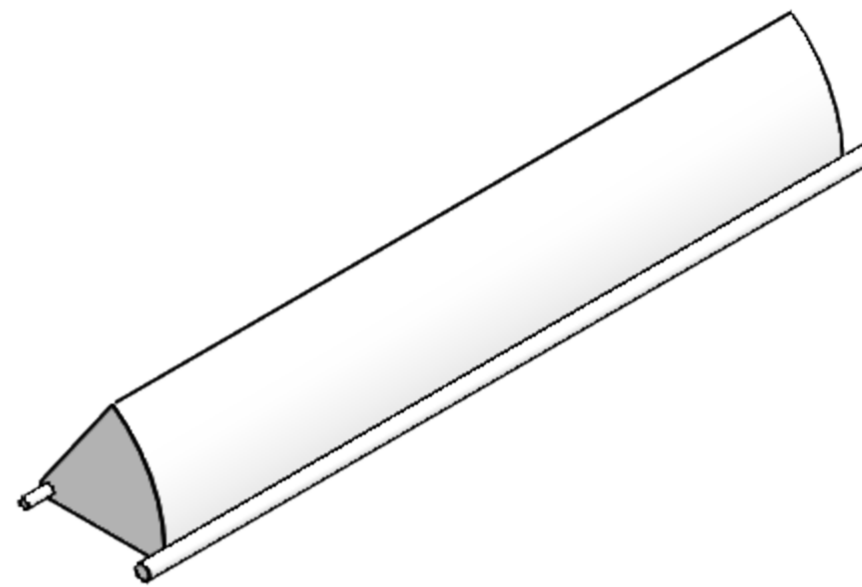
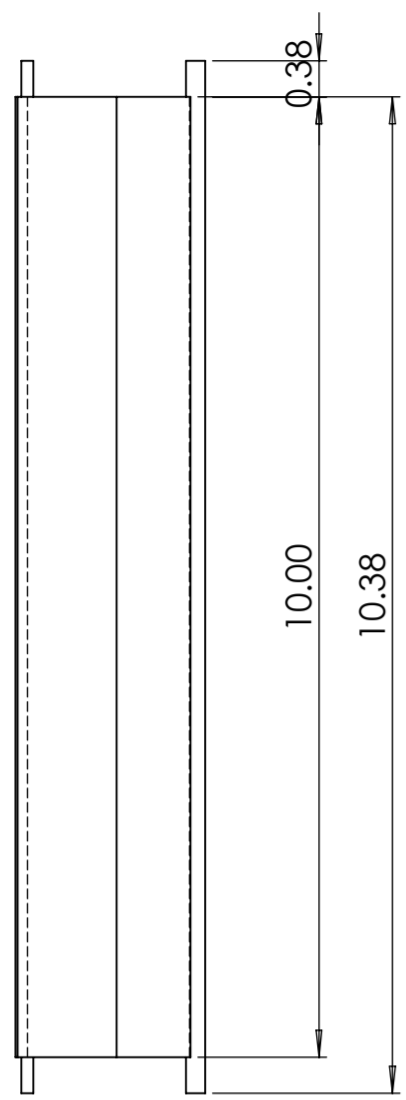

UNLESS OTHERWISE SPECIFIED: DIMENSIONS ARE IN INCHES SURFACE FINISH: 3D PRINTED				FINISH:		DEBURR AND BREAK SHARP EDGES		DO NOT SCALE DRAWING		REVISION	
								TITLE: LIFT STEP			
DRAWN				NAME		SIGNATURE		DATE		DWG NO. LS10B019	
CHK'D										A2	
APPV'D										SCALE:1:2	
MFG										SHEET 1 OF 1	
Q.A								MATERIAL: ABS		WEIGHT: 0.71	

12 11 10 9 8 7 6 5 4 3 2 1

H
G
F
E
D
C
B
A

H
G
F
E
D
C
B
A

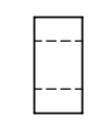
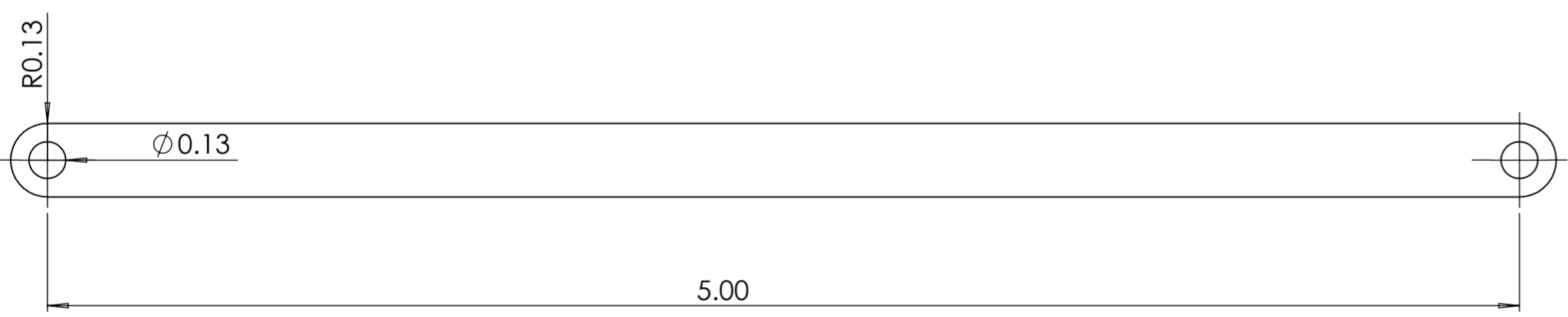
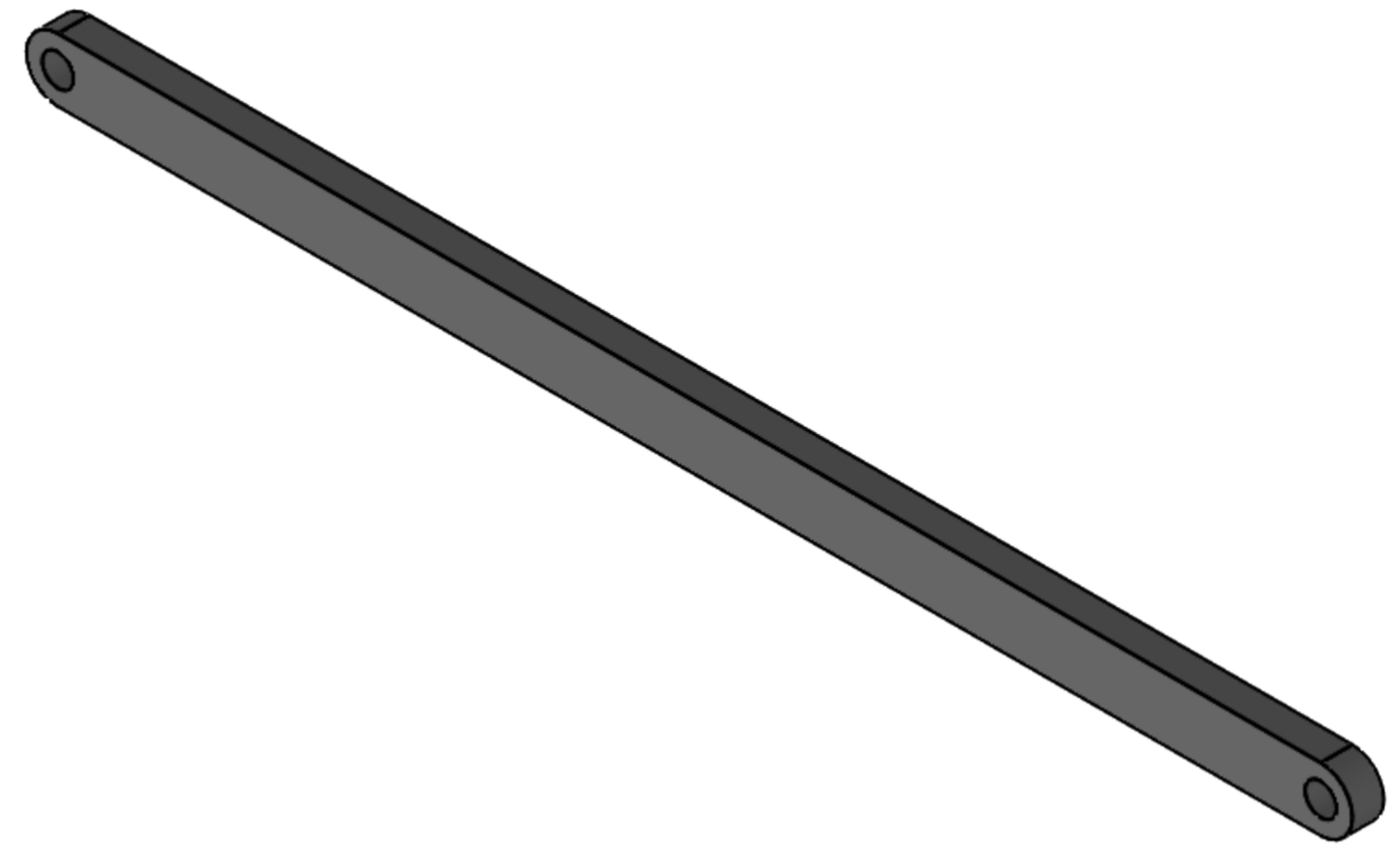
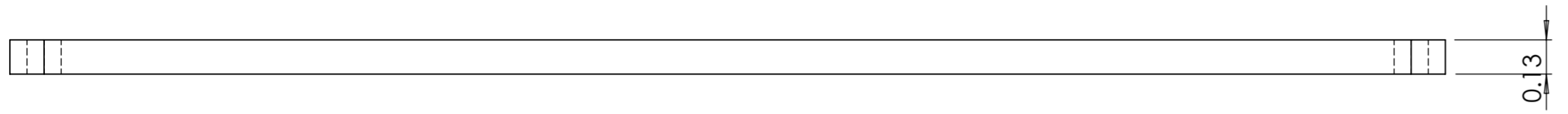

UNLESS OTHERWISE SPECIFIED: DIMENSIONS ARE IN INCHES SURFACE FINISH: 3D PRINTED				FINISH:		DEBURR AND BREAK SHARP EDGES		DO NOT SCALE DRAWING		REVISION		
								TITLE: SERVO LINKAGE				
								MATERIAL: ABS		DWG. NO. LS10B024		A2
								WEIGHT: 0.01		SCALE: 2:1		SHEET 1 OF 1
DRAWN	NAME	SIGNATURE	DATE									
CHK'D												
APPV'D												
MFG												
Q.A												

12 11 10 9 8 7 6 5 4 3 2 1

12 11 10 9 8 7 6 5 4 3 2 1

H
G
F
E
D
C
B
A

H
G
F
E
D
C
B
A

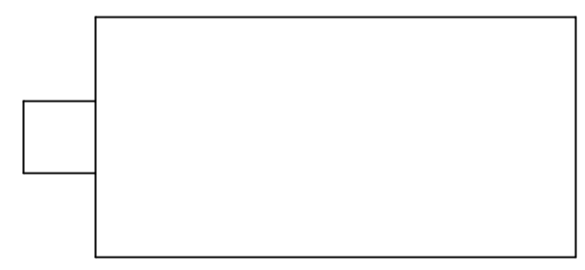
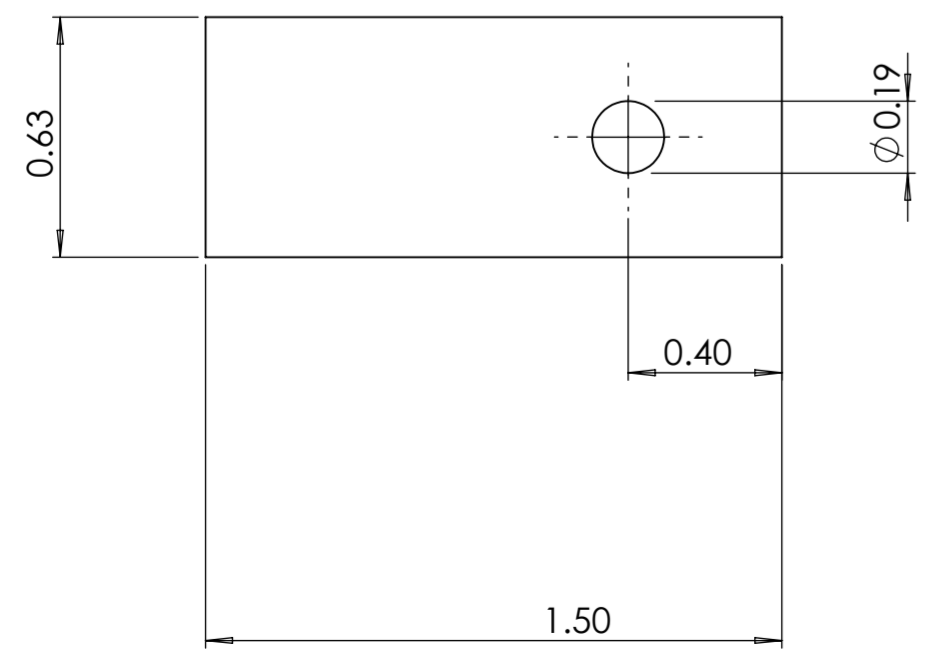
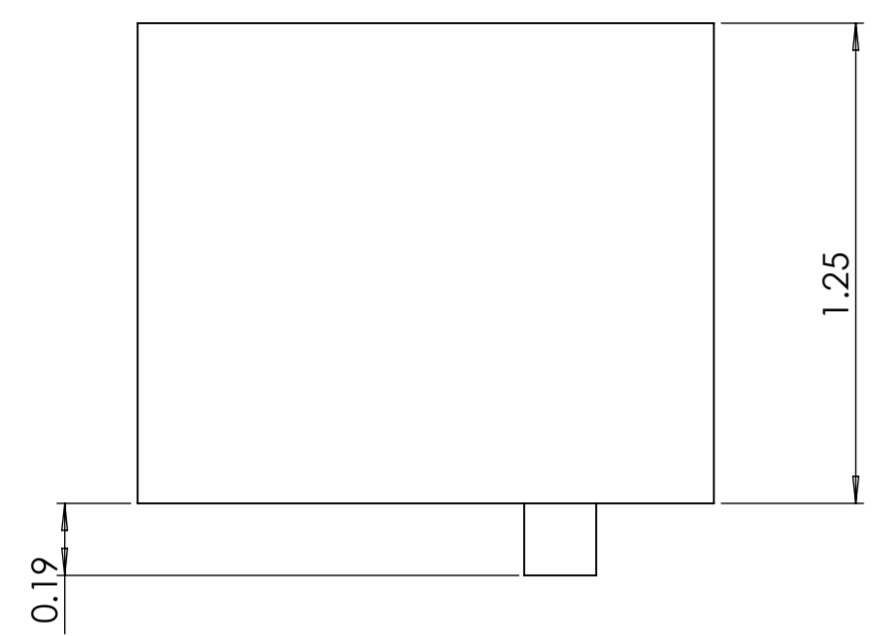
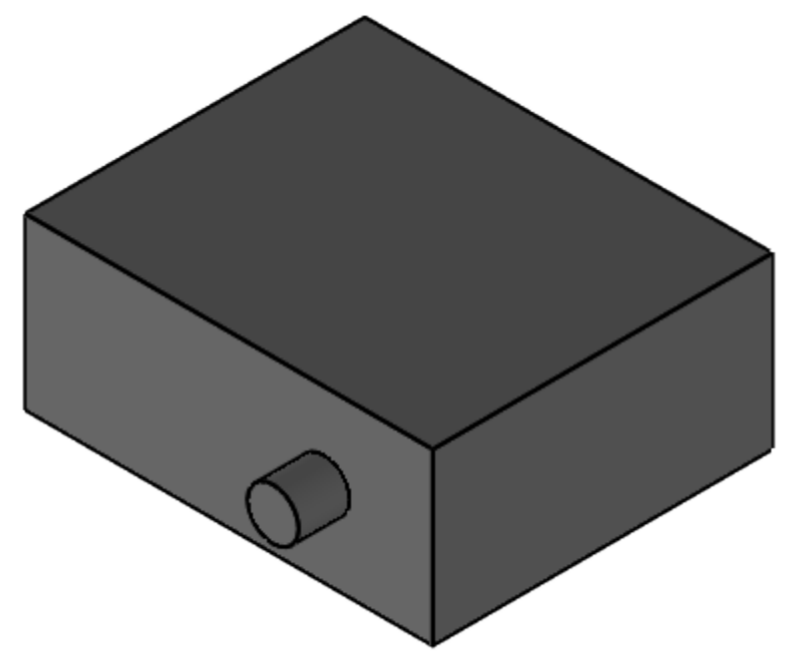

UNLESS OTHERWISE SPECIFIED: DIMENSIONS ARE IN INCHES				FINISH:		DEBURR AND BREAK SHARP EDGES		DO NOT SCALE DRAWING		REVISION	
								TITLE: SERVO			
DRAWN				NAME		SIGNATURE		DATE		DWG. NO. TBD	
CHK'D										A2	
APP'VD										SCALE:2:1	
MFG										SHEET 1 OF 1	
Q.A								MATERIAL:		WEIGHT:	

12 11 10 9 8 7 6 5 4 3 2 1

12 11 10 9 8 7 6 5 4 3 2 1

H
G
F
E
D
C
B
A

H
G
F
E
D
C
B
A

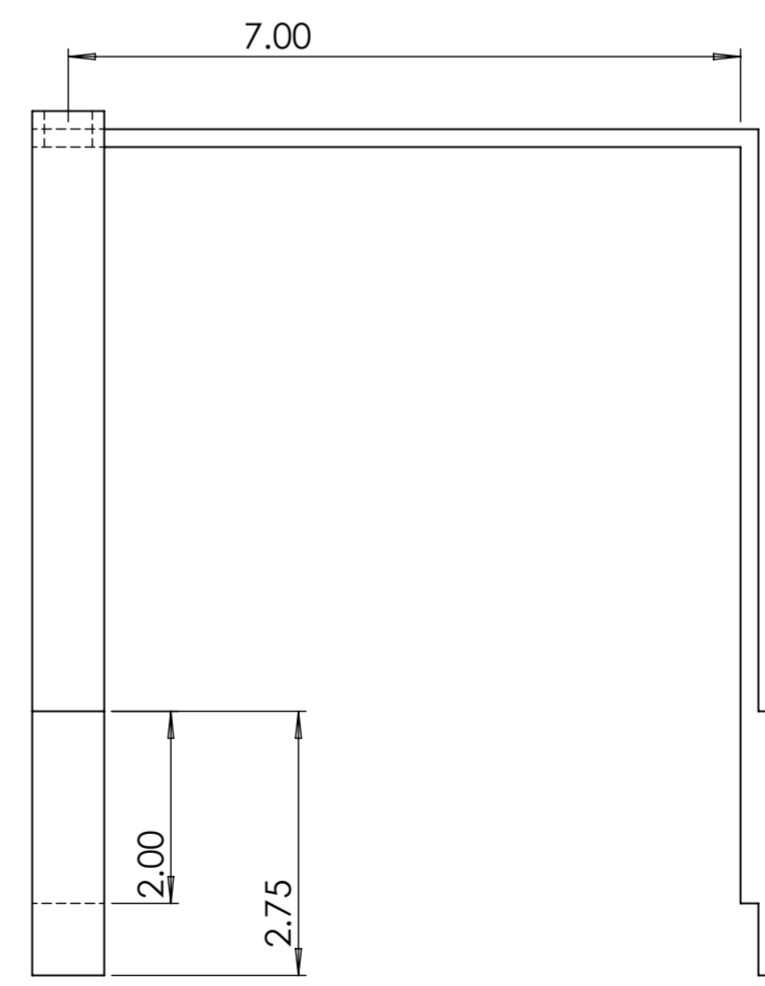
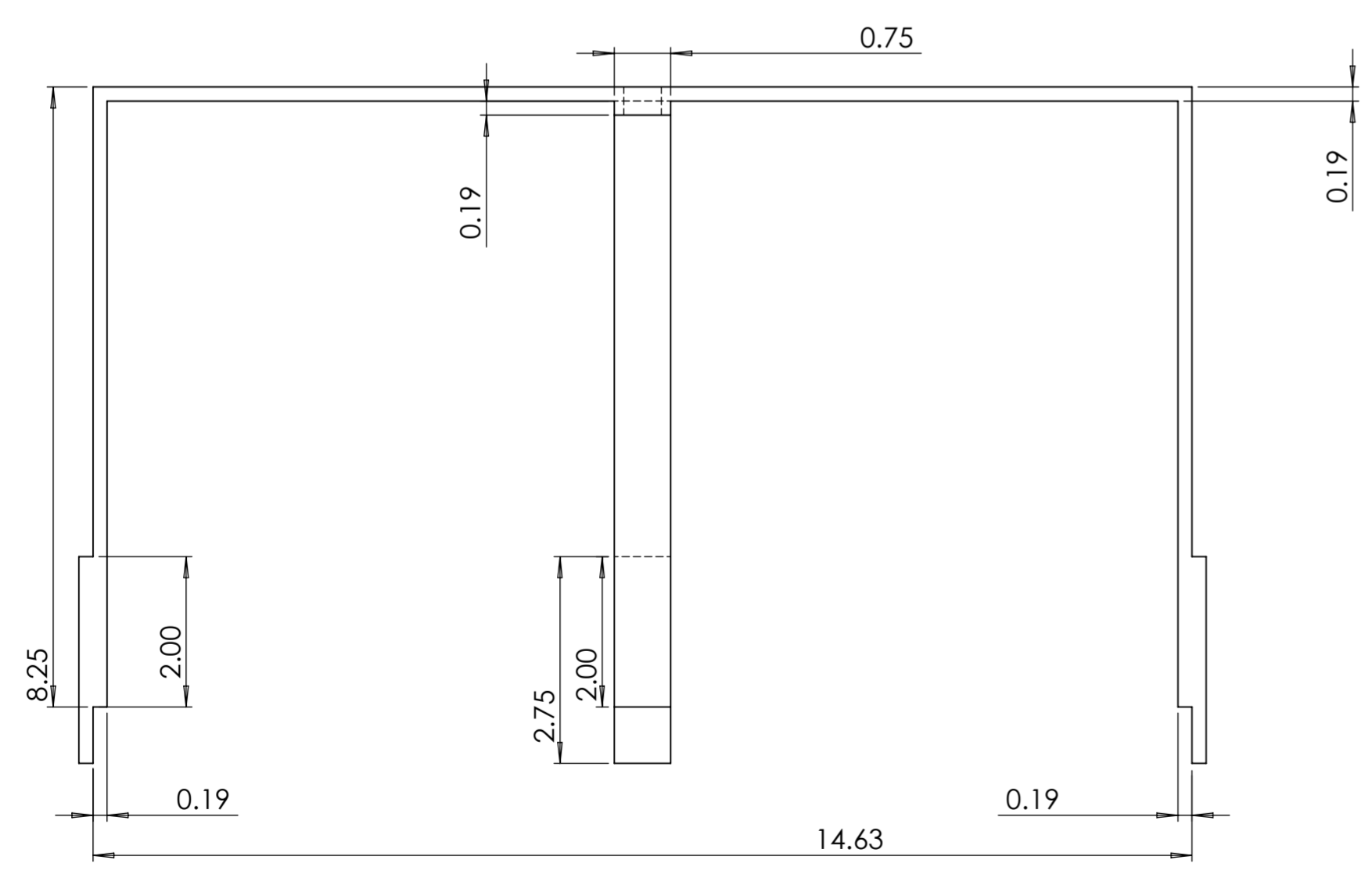
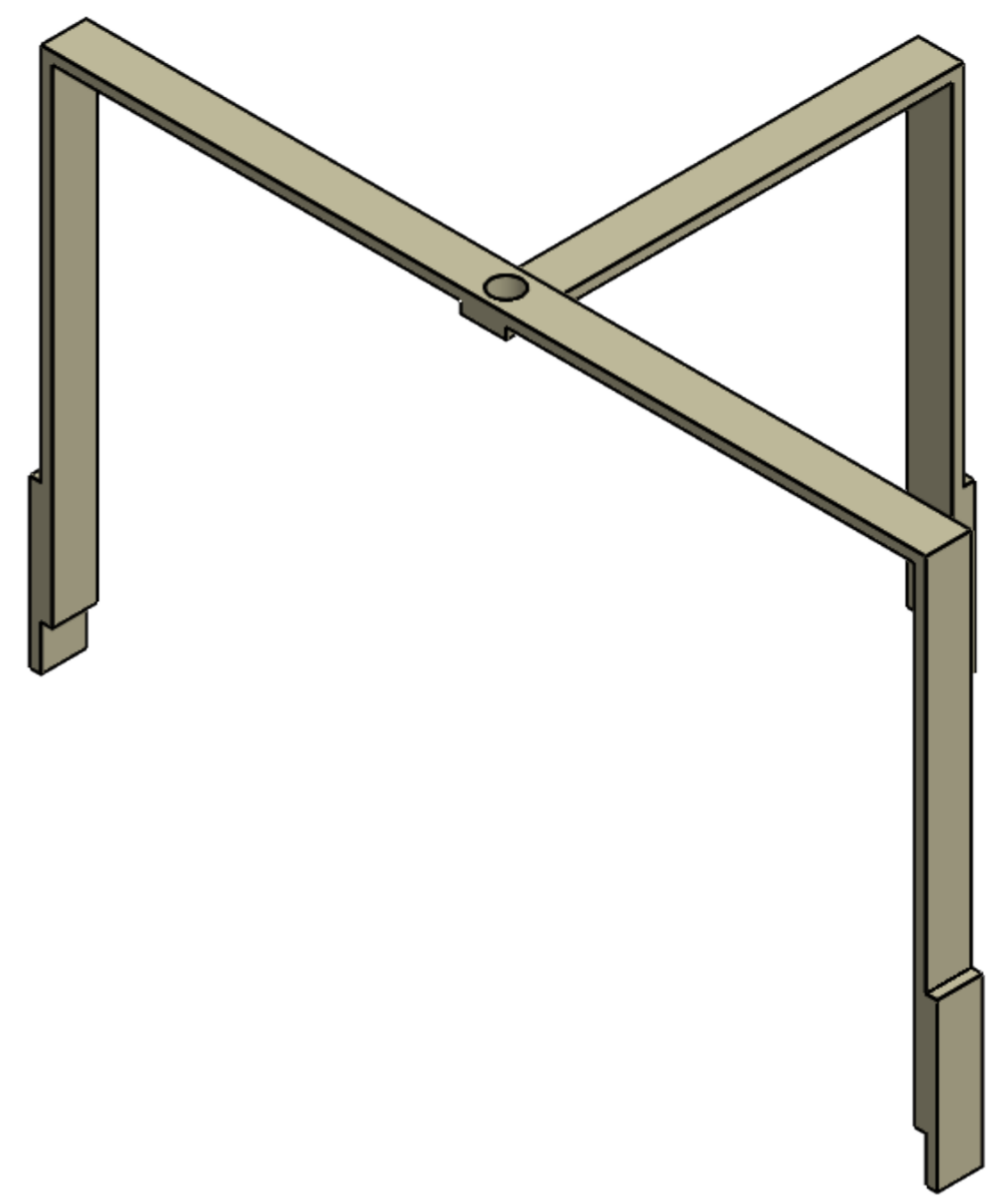
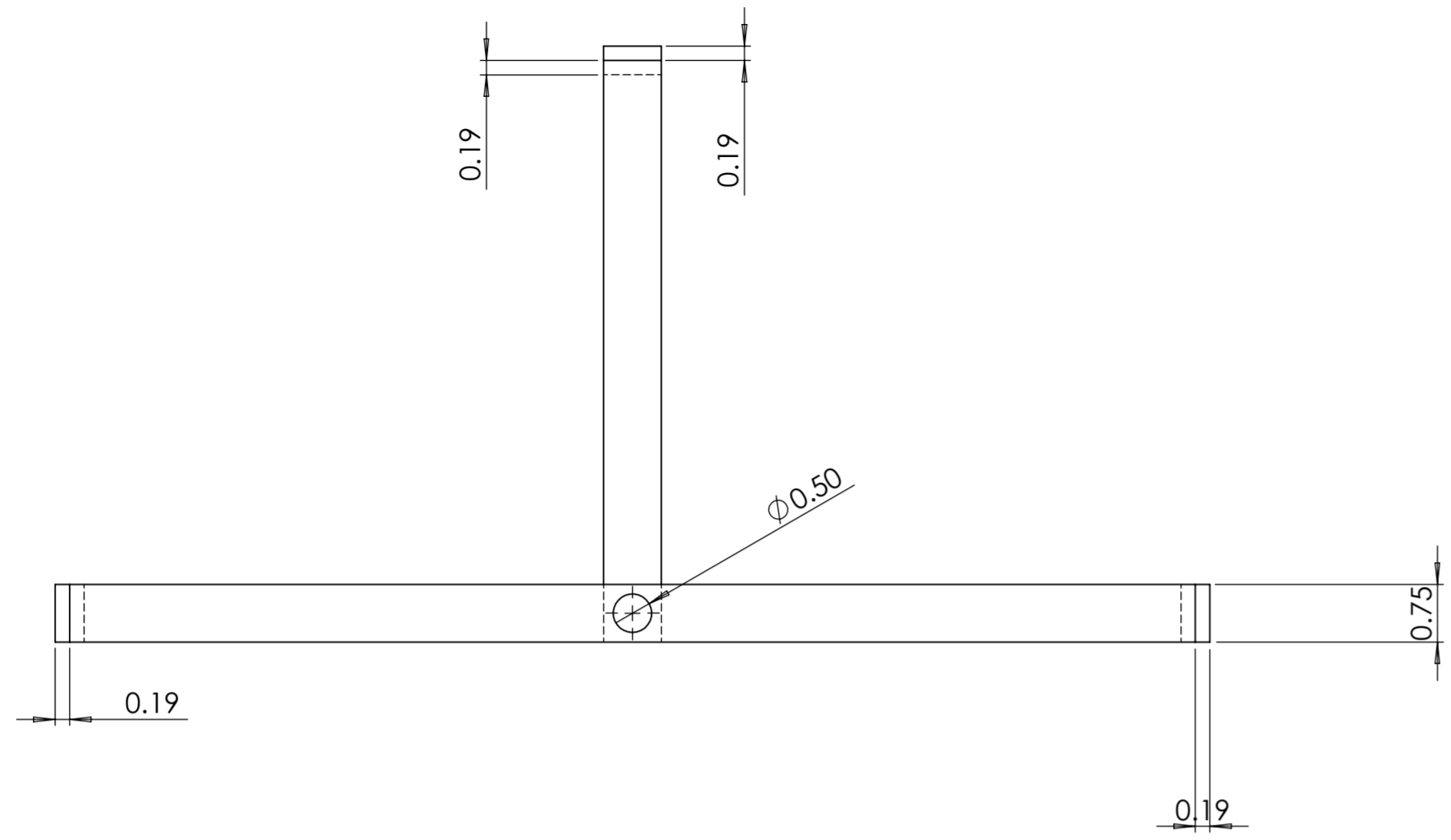

UNLESS OTHERWISE SPECIFIED: DIMENSIONS ARE IN INCHES SURFACE FINISH: BRUSHED				FINISH:		DEBURR AND BREAK SHARP EDGES		DO NOT SCALE DRAWING		REVISION	
DRAWN								TITLE: SLIDE BRACKET			
CHK'D								DWG NO. LS10B025			
APPV'D								SCALE: 1:2			
MFG								SHEET 1 OF 1			
Q.A.								A2			
MATERIAL: 1060-H12 Rod (SS)								WEIGHT: 0.74			

12 11 10 9 8 7 6 5 4 3 2 1

12 11 10 9 8 7 6 5 4 3 2 1

H
G
F
E
D
C
B
A

H
G
F
E
D
C
B
A

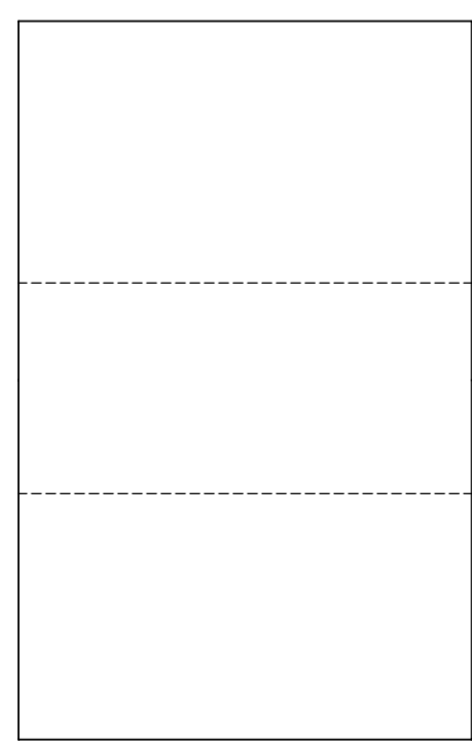
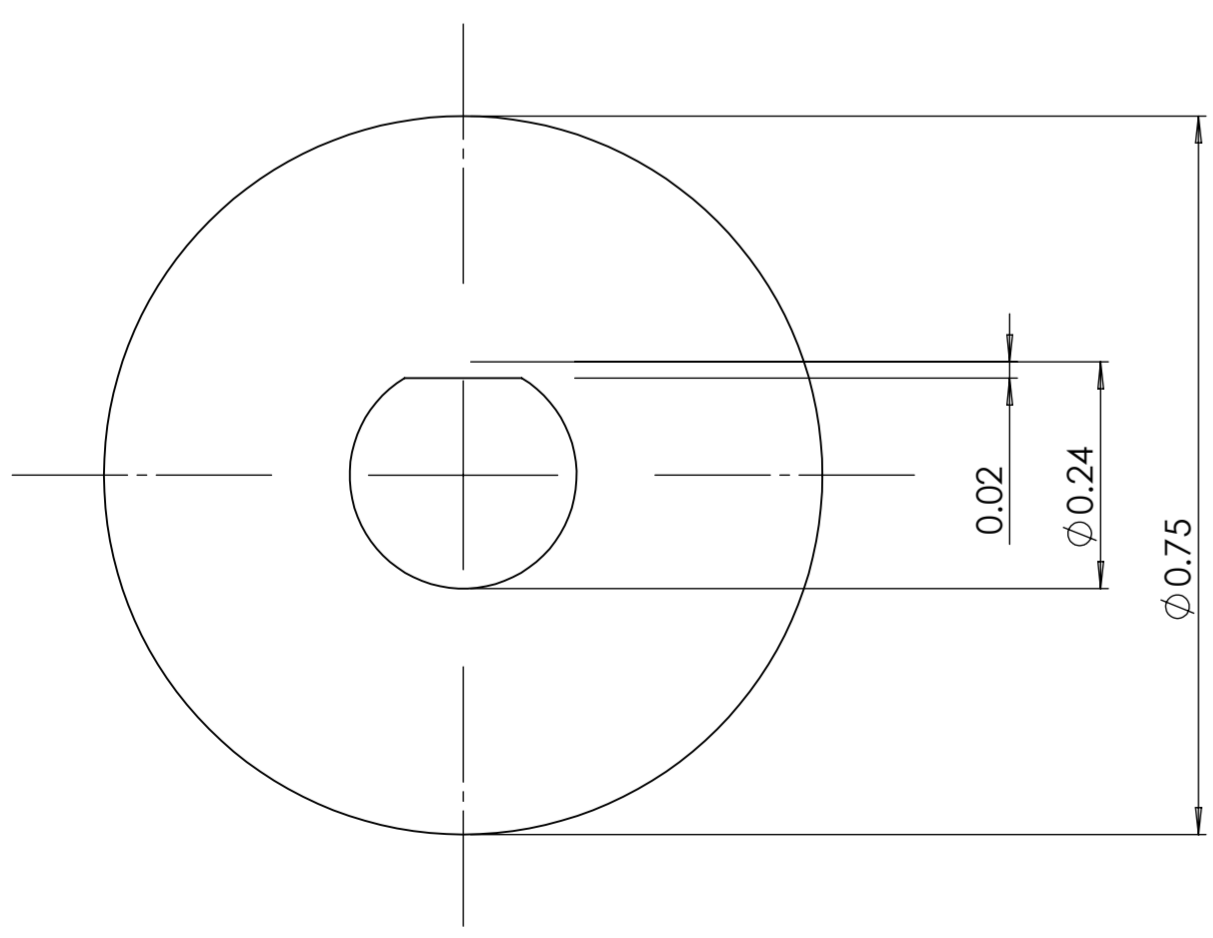
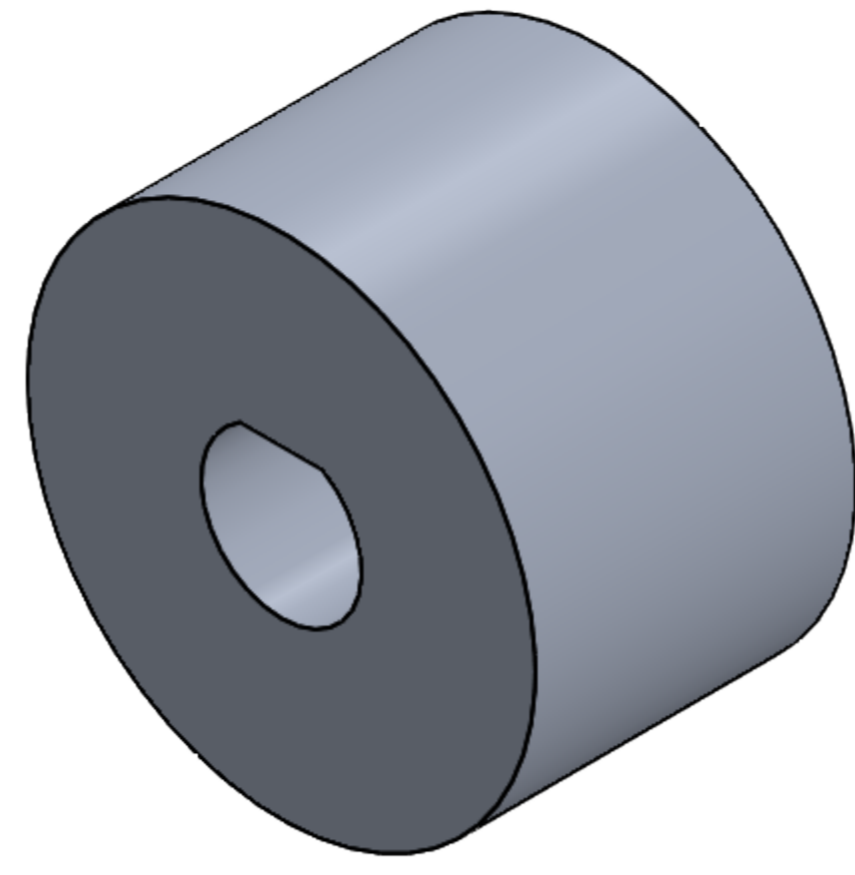
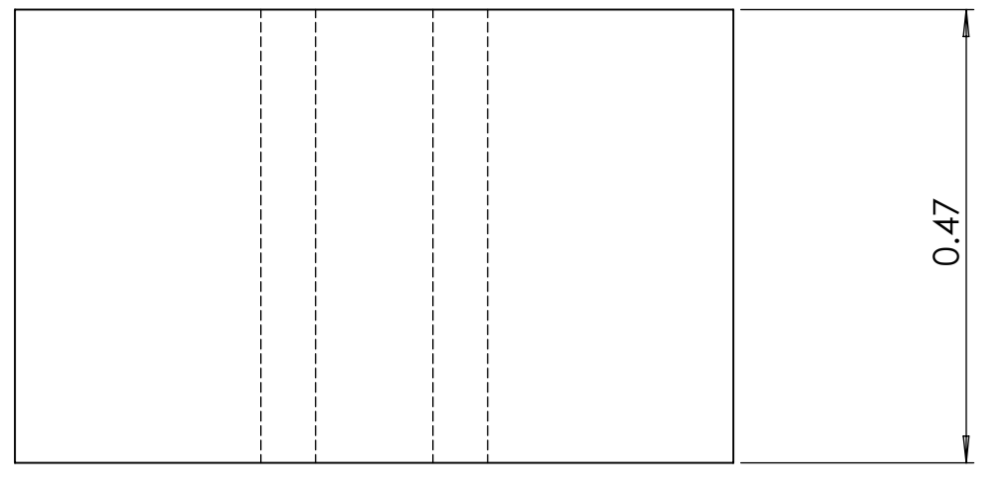

UNLESS OTHERWISE SPECIFIED: DIMENSIONS ARE IN INCHES SURFACE FINISH: POLISHED				FINISH:		DEBURR AND BREAK SHARP EDGES		DO NOT SCALE DRAWING		REVISION			
								TITLE: MOTOR BUSHING					
								MATERIAL: 1060 Alloy		DWG. NO. LS10B020		A2	
								WEIGHT: 0.02		SCALE: 1:1		SHEET 1 OF 1	
DRAWN	NAME	SIGNATURE	DATE										
CHK'D													
APPV'D													
MFG													
Q.A													

12 11 10 9 8 7 6 5 4 3 2 1

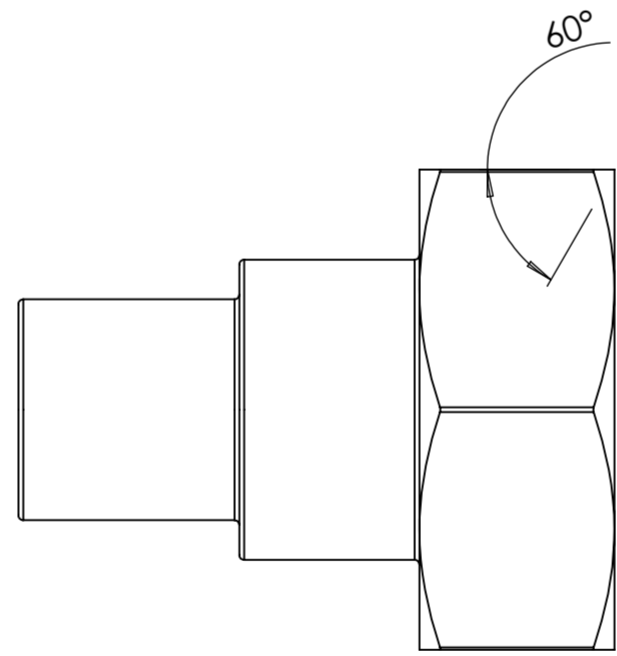
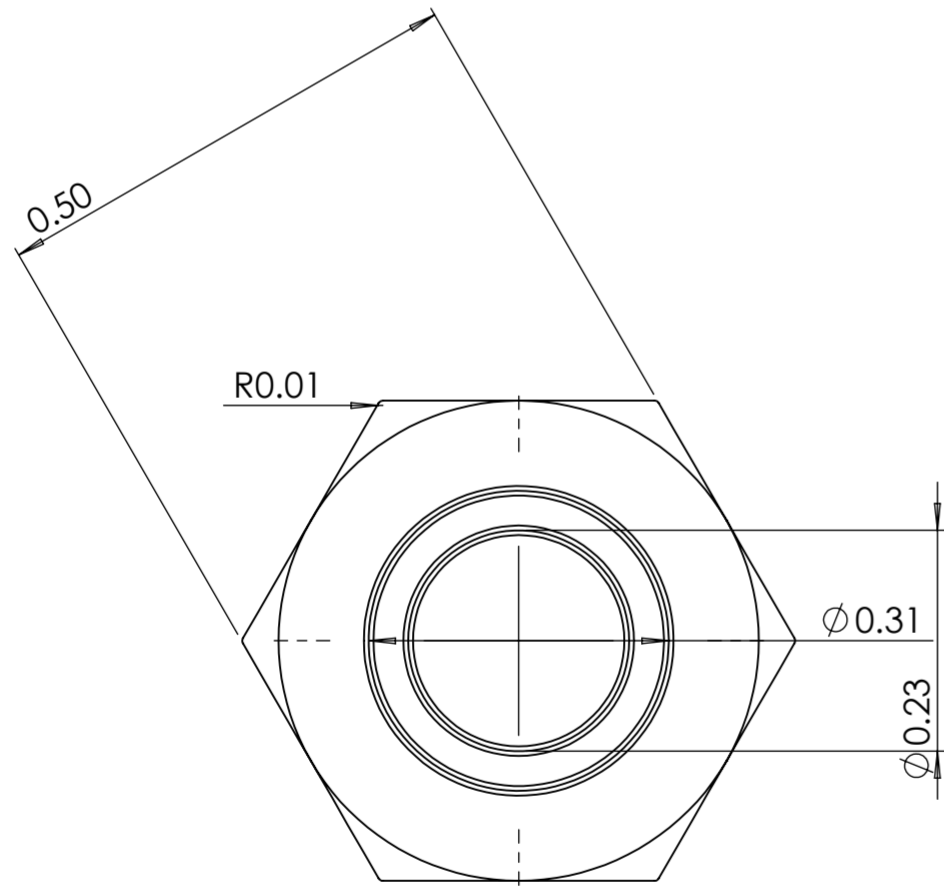
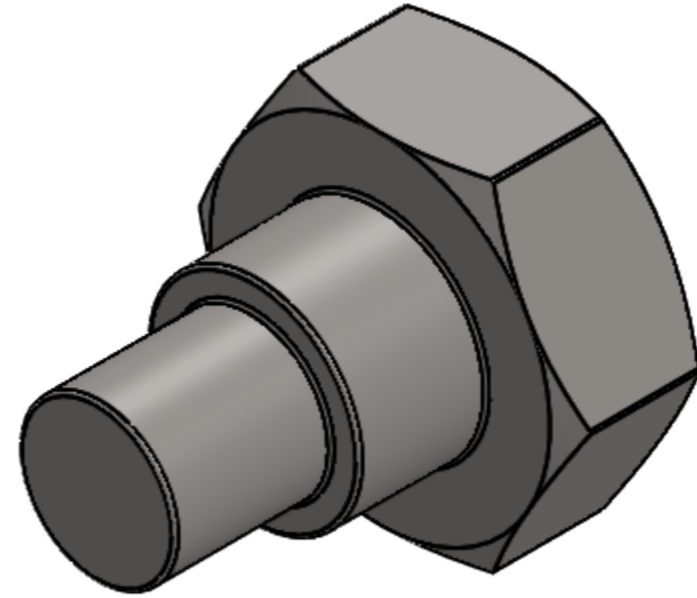
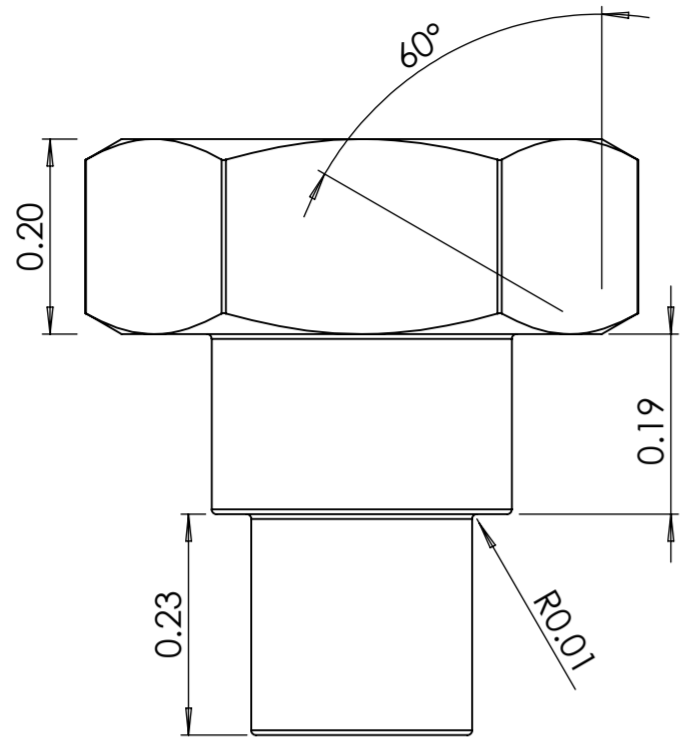

UNLESS OTHERWISE SPECIFIED: DIMENSIONS ARE IN INCHES				FINISH:		DEBURR AND BREAK SHARP EDGES		DO NOT SCALE DRAWING		REVISION	
								TITLE: PIN			
DRAWN				NAME		SIGNATURE		DATE		DWG NO. LS10B022	
CHK'D										A2	
APPV'D										SCALE: 1:1	
MFG										SHEET 1 OF 1	
Q.A						MATERIAL: AISI 1020		WEIGHT: 0.02			

12 11 10 9 8 7 6 5 4 3 2 1

H
G
F
E
D
C
B
A

H
G
F
E
D
C
B
A

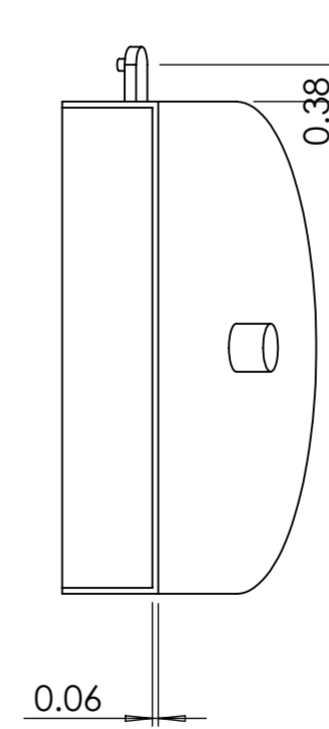
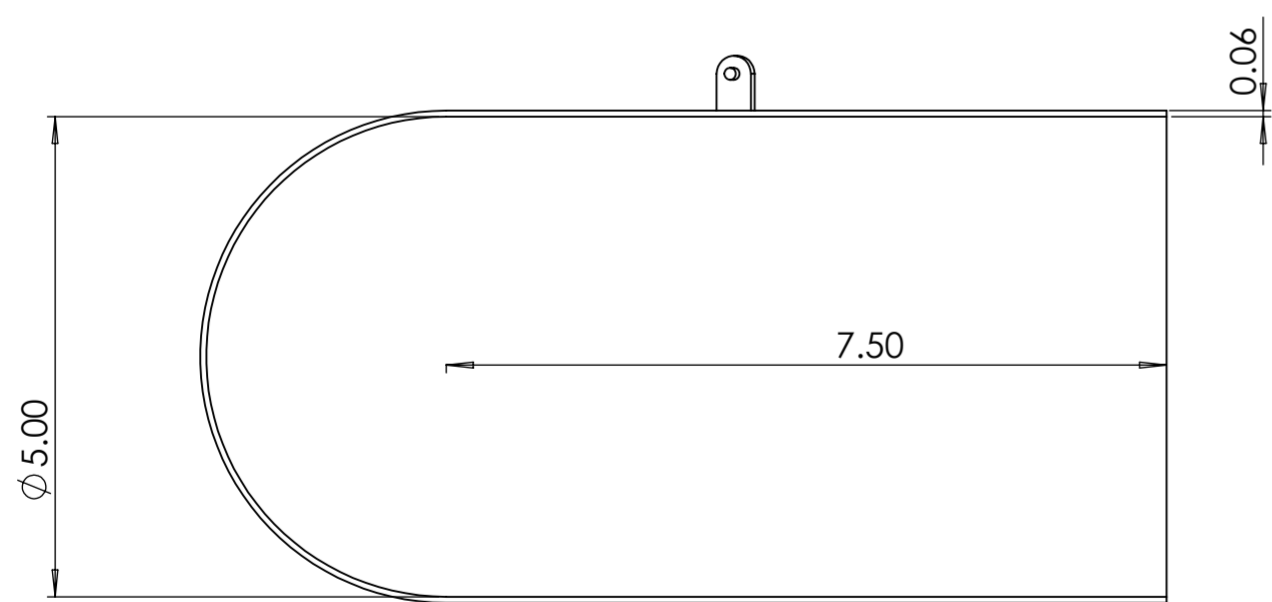
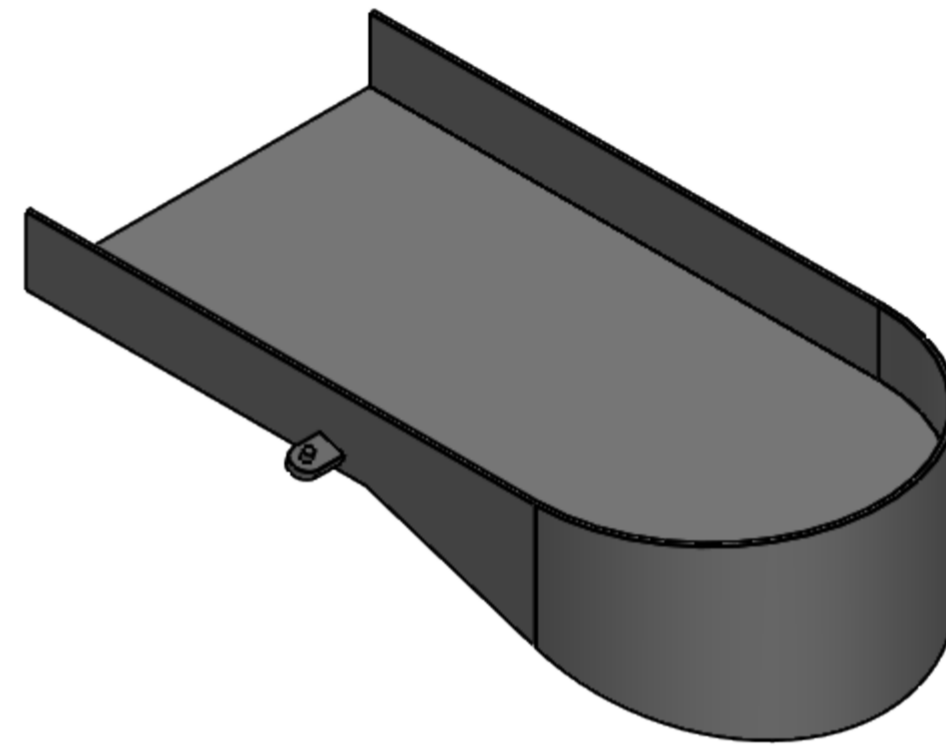
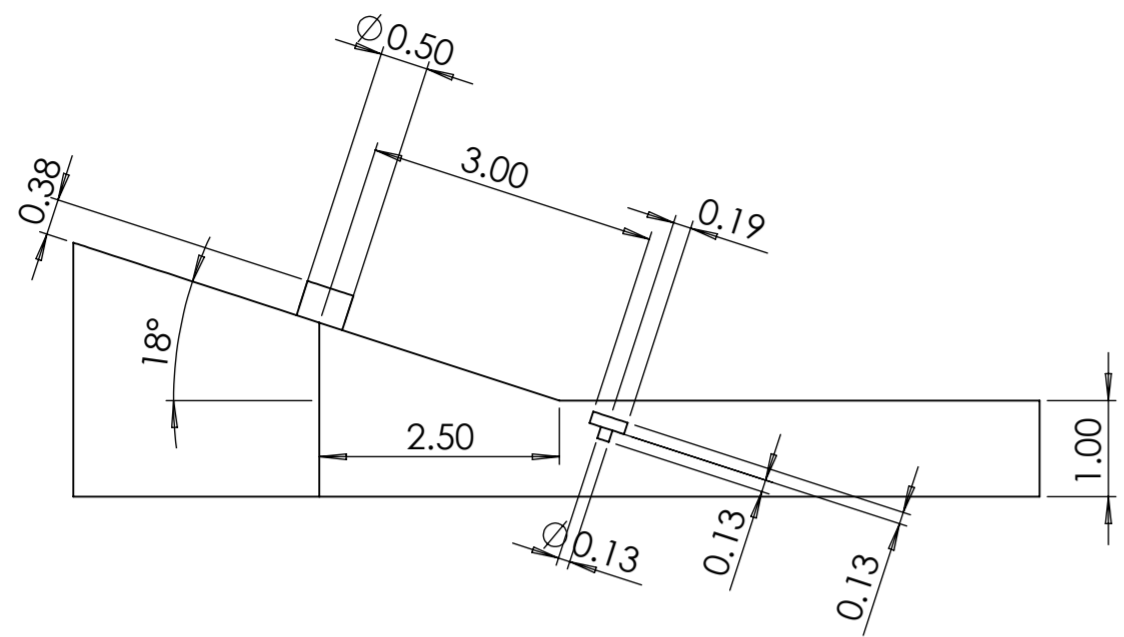

UNLESS OTHERWISE SPECIFIED: DIMENSIONS ARE IN INCHES SURFACE FINISH: 3D PRINTED			FINISH:		DEBURR AND BREAK SHARP EDGES		DO NOT SCALE DRAWING		REVISION		
DRAWN			NAME		SIGNATURE		DATE		TITLE: ROTATING ARM		
CHK'D											
APPV'D											
MFG											
Q.A									MATERIAL: ABS		DWG NO. LS10B023
									WEIGHT: 0.80		A2
									SCALE: 1:2		SHEET 1 OF 1

12 11 10 9 8 7 6 5 4 3 2 1

12 11 10 9 8 7 6 5 4 3 2 1

H
G
F
E
D
C
B
A

H
G
F
E
D
C
B
A

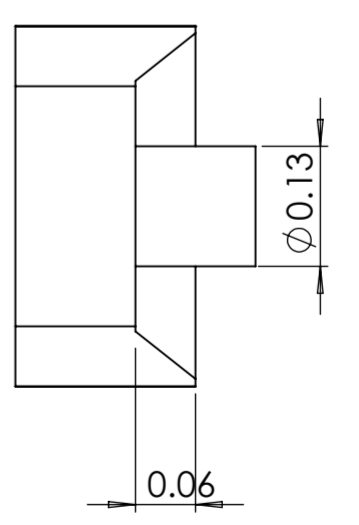
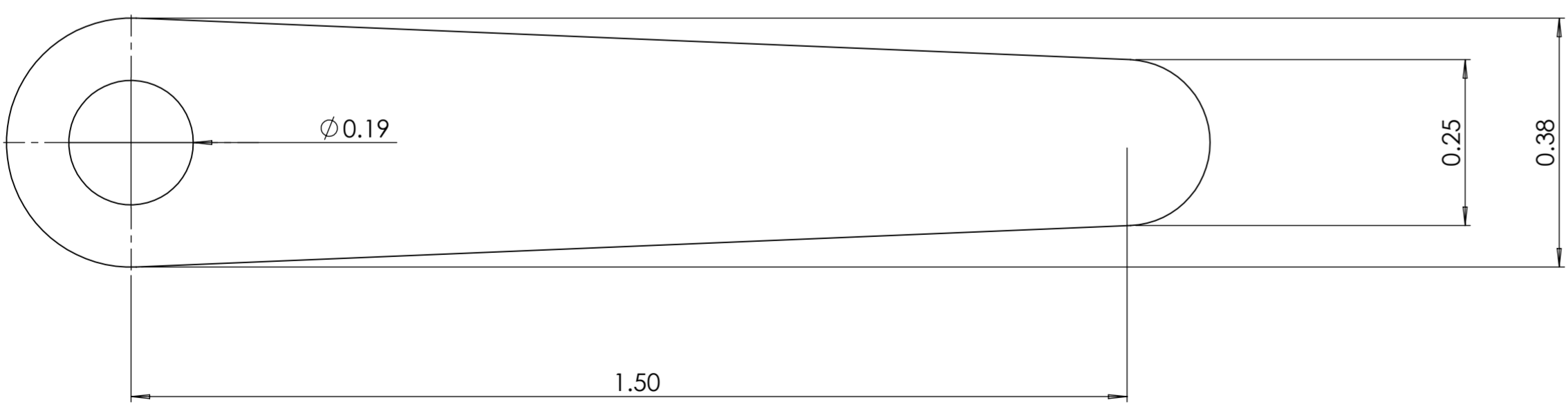
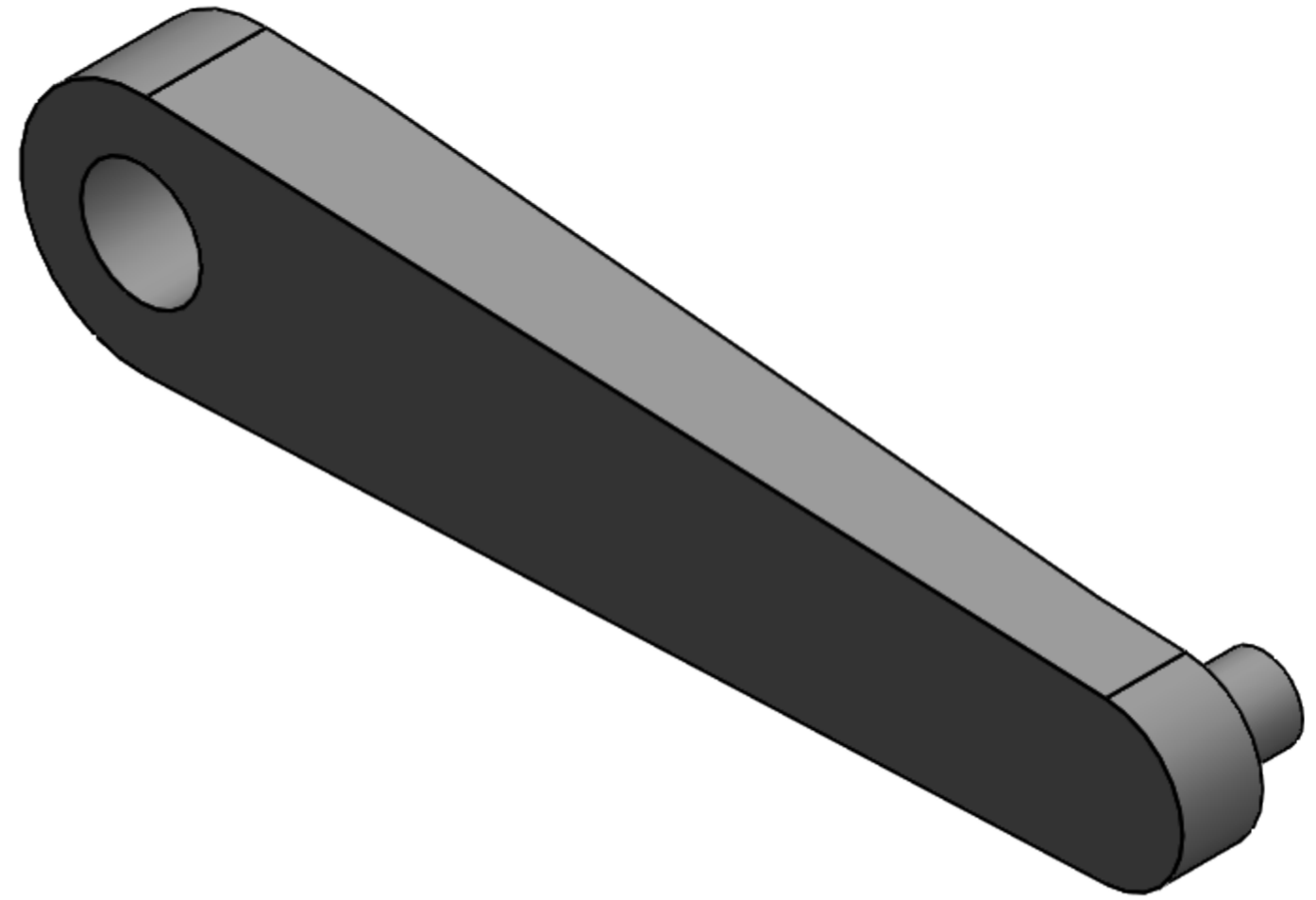
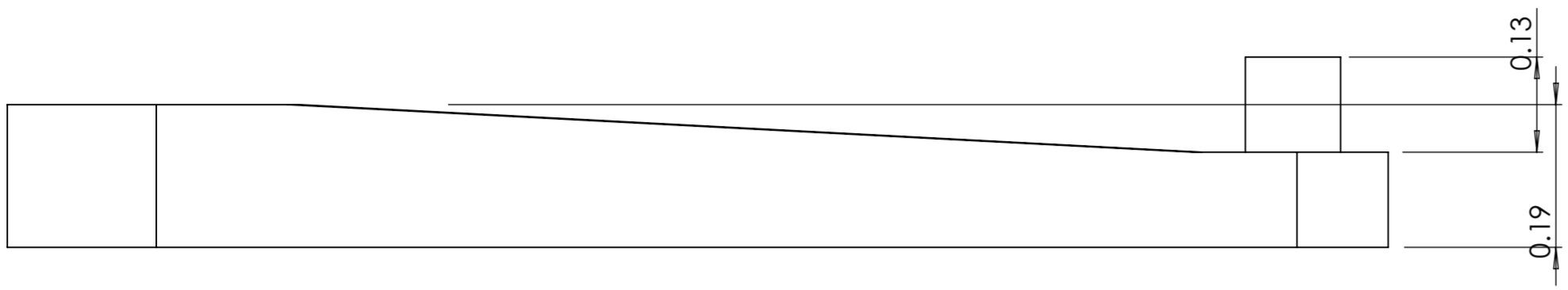

UNLESS OTHERWISE SPECIFIED: DIMENSIONS ARE IN INCHES SURFACE FINISH: 3D PRINTED				FINISH:		DEBURR AND BREAK SHARP EDGES		DO NOT SCALE DRAWING		REVISION		
								TITLE: SERVO ARM				
								MATERIAL: ABS		DWG NO. LS10B023		A2
								WEIGHT: 0.00		SCALE: S:1		SHEET 1 OF 1
DRAWN		NAME		SIGNATURE		DATE						
CHK'D												
APPV'D												
MFG												
Q.A												

12 11 10 9 8 7 6 5 4 3 2 1

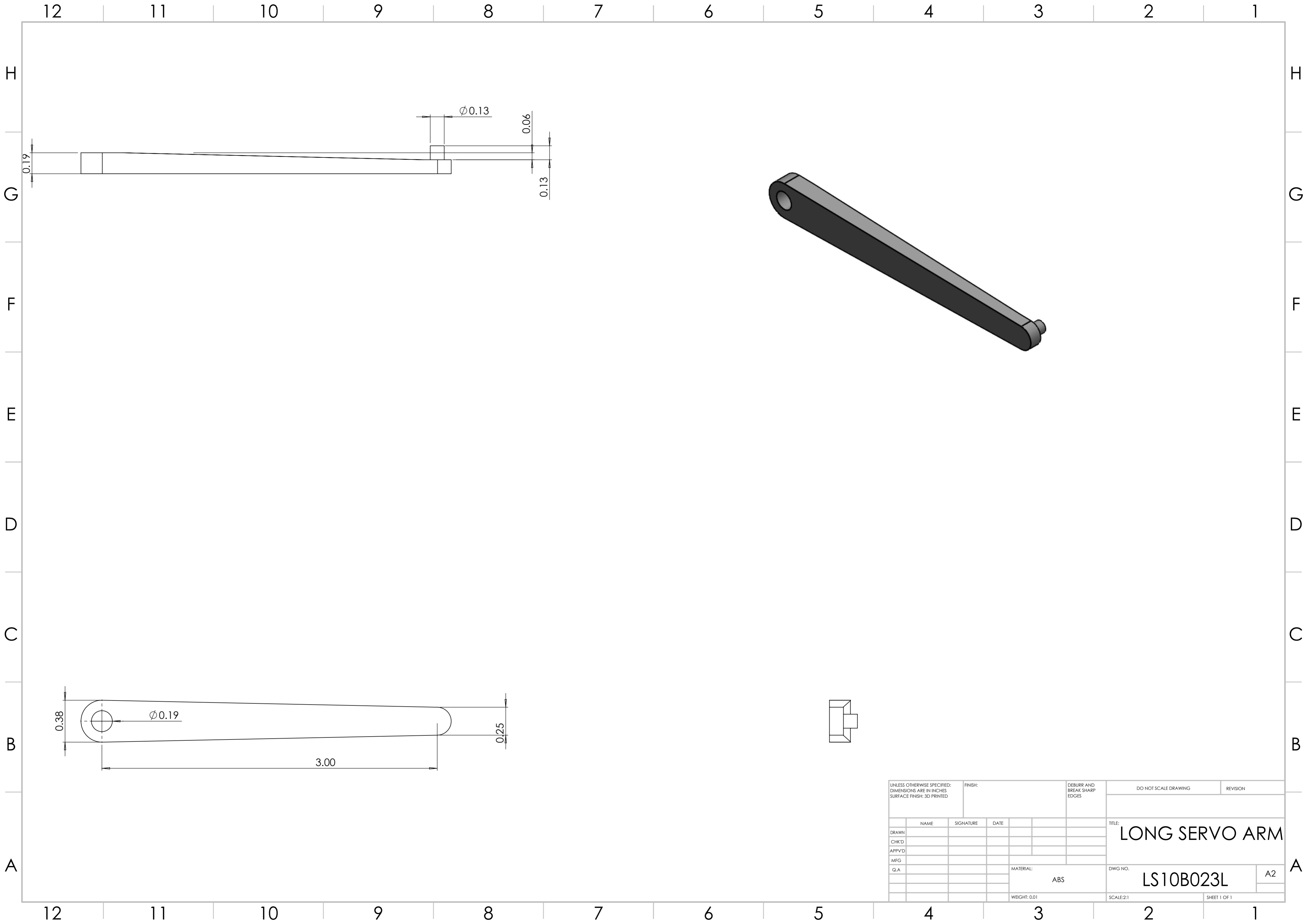

UNLESS OTHERWISE SPECIFIED: DIMENSIONS ARE IN INCHES SURFACE FINISH: 3D PRINTED				FINISH:		DEBURR AND BREAK SHARP EDGES		DO NOT SCALE DRAWING		REVISION		
								TITLE: LONG SERVO ARM				
								MATERIAL: ABS		DWG NO. LS10B023L		A2
								WEIGHT: 0.01		SCALE: 2:1		SHEET 1 OF 1